

wideyeTM

liberating communications

SAFARITM



SAFARITM USER GUIDE
REV 1.0

Table of Contents

Prefix	1
Safety Information	3
Copyright	5
Chapter 1	
Introduction	6
Chapter 2	
Using the Primary Handset	10
Chapter 3	
Using the Web Console	47
Chapter 4	
Connecting Devices with SAFARI™ Transceiver	99
Chapter 5	
Troubleshooting and FAQs	102
Appendix A	108
Appendix B	111

Federal Communication Commission Notice

FCC Identifier: QY9-WESAFARI

USE CONDITIONS:

This device complies with part 15 of the FCC Rules. Operation is subject to the following two conditions:

1. This device may not cause harmful interference.
2. This device must accept any interference received, including interference that may cause undesired operation.

NOTE:

This equipment has been tested and found to comply with the limits for a Class B digital device, pursuant to Part 15 of the FCC Rules. These limits are designed to provide reasonable protection against harmful interference in a residential installation. This equipment generates, uses and can radiate radio frequency energy and, if not installed and used in accordance with the instructions, may cause harmful interference to radio communications. However, there is no guarantee that interference will not occur in a particular installation.

If this equipment does cause harmful interference to radio or television reception, which can be determined by turning the equipment off and on, the user is encouraged to try to correct the interference by one of the following measures:

- Reorient or relocate the receiving antenna.
- Increase the separation between the equipment and receiver.
- Connect the equipment into an outlet on a circuit different from that to which the receiver is connected.
- Consult the dealer or an experienced radio/TV technician for help.

IMPORTANT NOTE: EXPOSURE TO RADIO FREQUENCY RADIATION

This Device complies with FCC radiation exposure limits set forth for an uncontrolled environment. The Antenna used for this transmitter must be installed to provide a separation distance of at least 100cm from all persons and must not be co-located or operating in conjunction with any other antenna or transmitter

FCC CAUTION:

Any Changes or modifications not expressly approved by the manufacturer could void the user's authority, which is granted by FCC, to operate this Inmarsat - Class 11, BGAN Land Mobile satellite system.

Industry Canada Statement

IC Identifier IC: 5023A-WESAFARI

This device complies with Radio standard specification RSS -170 issue 1, Revision 1:1999 and RSS-GEN issue 3:2010 , RSS 210 issue 8:2010 of Industry Canada Rules. Operation is subject to the following two conditions:

1. This device may not cause harmful interference, and
2. This device must accept any interference received, including interference that may cause undesired operation.

IMPORTANT NOTE: Radiation Exposure Statement

This equipment complies with IC radiation exposure limits set forth for an uncontrolled environment. This antenna used for this transmitter must be installed to provide a separation distance of at least 100cm from all persons and must not be co-located or operating in conjunction with any other antenna or transmitter.

EC Declaration of Conformity:

Addvalue Communications Pte Ltd, 28 Tai Seng Street, #06-02, Singapore 534106 declares under our sole responsibility that the Product, brand name as Wideye and model: SAFARI , Inmarsat BGAN Land mobile satellite communication system, to which this declaration relates, is in conformity with the following standards and/or other normative documents:

ETSI EN 301 444, ETSI EN 301 328, ETSI EN 301 489-1,-17, -19 &- 20, ITU-R M.1480, IEC 60950-1 and EN 60950-1,

We hereby declare that all essential radio test suite have been carried out and that the above named product is in conformity to all the essential requirements of Directive 1999/5/EC.

The Conformity Assessment procedure referred to Article 10 and detailed in Annex [III] or [IV] of Directive 1999/5/EC has been followed with involvement of the following notified body (ies):

TIMCO ENGINEERING, INC., P.O BOX 370, NEW BERRY, FLORIDA 32669.
Identification mark: **1177** (Notified Body number)



The technical documentation relevant to the above equipment are held at:

- Addvalue Communications Pte Ltd, 28 Tai Seng Street, #06-02, Singapore 534106.
- Signed by Mr. Tan Khai Pang (Chief Technology Officer, 26th July, 2011) and
- Mr. Prabakar Kuttaniseeri (Quality Engineering Manager, 26th July, 2011).

Safety Summary

For the sake of safety and protection, please read the user guide before you attempt to use the SAFARI™ Transceiver. In particular, read this safety section carefully. Keep this safety information where you can refer to it if necessary.

The following general safety precautions must be observed during all phases of operation, service and repair of this equipment. Failure to comply with these precautions or with specific warnings elsewhere in this user guide violates safety standards of design, manufacture and intended use of the equipment.

Addvalue Communications Pte Ltd assumes no liability for the customer's failure to comply with these requirements.

Hazard Symbols

Avoid touching those areas of the Transceiver during operation that are being marked with this symbol otherwise it may result in injury.



Antenna Radiation Warning

During transmission the antenna in the system radiates high power levels of radio frequency. This radiation is considered health hazardous to any personnel that come close to the antenna.

It is important to maintain a separation distance from the transmitting antenna to any personnel of at least 1-meter.



Distance to Other Radiation Equipment

The antenna shall not be installed near any VSAT or radar at the minimum distance and position specified in the later chapter of the user guide. It may cause damage or interference to the antenna.

Service

User access to the interior of the transceiver is not allowed. Only a qualified personnel authorized by its manufacturer may perform service. Failure to comply with this rule will result in the warranty void.

Grounding and Antenna Cables

The transceiver has provided its mechanical stud, which is intended for the grounding wire to be connected to the body of the vehicle.

The antenna cable between the transceiver and antenna can be extended with specified distance as long as it can meet any type of antenna's characteristic data, which does not exceed its required attenuation.

The antenna cable is shielded and it should not be affected by any magnetic field. It is recommended to avoid the cable being installed in parallel with any AC wiring as it may possibly cause malfunction of the equipment.

Power Supply

The input DC voltage for SAFARITM Transceiver is +10.8V DC to +32V DC.

In case of unavailability DC power line provided, an external AC/DC power supply of 115/230V AC with its output of +24V DC, 5A minimum can be used. Please note that the requirements of the AC/DC power supply should take care of **high surge current of 25A at 24V DC for 1ms**.

Equipment Ventilation

To ensure adequate cooling of the transceiver, 5-centimeter of unobstructed space must be maintained around all sides of the unit except the bottom side. The ambient temperature range of the transceiver is: -25°C to +55°C.

The equipment shall not be operated in the presence of flammable gases or fumes as well as any explosive atmosphere. Operation of any electrical equipment in such an environment constitutes a definite safety hazard.

Keep Away from Live Circuits

Operating personnel shall not remove equipment covers. Component replacement and internal adjustment has to be handled by qualified maintenance personnel. Do not attempt to replace components with the power cable connected. Under certain conditions, dangerous voltages may exist even with the power cable removed. To avoid injuries, always disconnect power and discharge circuits before touching them.

Obtaining Licensing For Inmarsat Transceivers

Under rights given under ITU Radio Regulations, local telecommunications administrations establish and enforce national rules and regulations governing types of emissions, power levels, and other parameters that affect the purity of signal, which may be radiated in the various frequency bands of the radio spectrum.

To legally operate Inmarsat equipment, it is necessary to obtain permission from the local telecommunications regulatory authorities of the country you are operating from. Using your equipment in any country without permission causes you to run the risk of confiscation of the equipment by the local authorities. The normal procedure to bring such equipment into another country is to apply for a license before travel. If a license has not been obtained before travel, the equipment may be put in to storage by local authorities until such time license is obtained.

Copyright

© Copyright 2011 Addvalue Communications Pte Ltd

All rights reserved. This publication and its contents are proprietary to Addvalue Communications Pte Ltd. No part of this publication may be reproduced in any form or by any means without the written permission of Addvalue Communications Pte Ltd.

Warranty

Addvalue Communications Pte Ltd has made every effort to ensure the correctness and completeness of the material in this document. Addvalue Communications Pte Ltd shall not be liable for errors contained herein. The information in this document is subject to change without notice. Addvalue Communications Pte Ltd makes no warranty of any kind with regard to this material, including, but not limited to, the implied warranties of merchantability and fitness for a particular purpose.

Trademarks

All trademarks, marks, names, or product names referenced in this publication are the property of their respective owners, and Addvalue Communications Pte Ltd neither endorses nor otherwise sponsors any such products or services referred to herein.

Microsoft, Windows, Windows NT, Windows 2000, Windows XP and Windows 7 are registered trademarks of Microsoft Corporation in the U.S.A. and/or other countries.

INMARSAT is a trademark of the International Mobile Satellite Organization. The Inmarsat LOGO and the trademark BGAN are trademarks of Inmarsat (IP) Company Limited. All trademarks are licensed to Inmarsat Limited.

All other company and product names may be the registered trademarks or trademarks of their respective owners.

1 Introduction



The SAFARI™ is a Land Vehicular BGAN Terminal operating on the Inmarsat BGAN Satellite Network.

The SAFARI™ has one of the smallest Land Vehicular BGAN antennas in the market at 252mm Dia x 119.12mm H (9.9 in. Dia x 4.7 in. H) and weighs only 1.9kg (4.2lbs.). The complete system consists of three fully integrated units – an IP44 rated Transceiver Unit (TU) with built-in Wi-Fi, an IP66 rated Handset and an IP56 rated roof mounted Antenna Unit (AU). The Antenna Unit is compact and lightweight, ideal for vehicles on-the-move. It has been designed for the most demanding environments – and is easy to carry when travelling to various locations around the world.

The SAFARI™ Land vehicular BGAN Terminal offers the user standard voice (4kbps AMBE+2), optional 3.1 KHz high quality voice/fax, high speed Streaming and Standard IP data service for various application, including internet browsing, email and file transfer functions.

The terminal allows simultaneous use of all services including voice/fax, data and SMS. Physical interfaces include, 2 x RJ-11 for Voice and Fax, 2 x RJ45 for Ethernet LAN connections, a RS232 port for GPS output and 4 x GPIOs, for external control or indications.

Special Features

- Forced Dialing
- Restricted Dialing
- Call Prioritisation
- Remote Access
- Backup/Restore of Configuration Settings
- Remote Transmitter Off via GPIO
- SIM Lock based on IMSI/DP Code/SP Code/APN
- Multilingual WebConsole (English, Spanish, Chinese (Simplified & Traditional))
- Multi-User access with configurable access rights
- Time/Volume limited data sessions
- MAC filtering
- Port Forwarding

The antenna has built-in magnetic roof mounts. Simply place the antenna Unit on the roof of the vehicle, connect it to the Transceiver Unit and connect the SAFARI™ to the vehicle's power source, The vehicle is now a mobile communications hub, which multiple users can access at the same time via the wired interfaces and the standard built-in Wi-Fi feature. The SAFARI™ is so versatile that the built-in WebConsole of the unit can be accessed via any web browser including Wi-Fi-enabled Smartphones such as BlackBerrys, iPhones, iPads, and PDAs via the SAFARI™'s secure Wi-Fi connections.

The SAFARI™ also has a continuous GPS output feature which allows for GPS data to be sent out via the RS232 port in standard NMEA 0183 format. With in-built GPS module, SAFARI™ is able to provide tracking and monitoring required in fleet management applications.

Technical Specifications

- Type Approval Certificate
- Certification mark: FCC, CE, Industry Canada
- GMPCS MoU – ITU REGISTRY
- Compliant to RoHS, WEEE Logo
- Wi-Fi Complaint IEEE802.11b/g

Operating Frequency

- Transmit: 1626.5MHz – 1660.5MHz
- Receive: 1525MHz – 1559MHz

Transceiver Unit to Antenna Unit RF Cabling max loss

- 12dB at 1.6GHz and 4 Ohms DC loop resistance

Services

- Voice: 4kbps AMBE +2
- Streaming IP: 32, 64 or 128kbps (send & receive)
- Short Message Service (SMS): Up to 160 characters (3G standard)
- Larger SMS content (>160 characters): supported as multipart or segmented SMS
- Background IP Data: Up to 448/464kbps (send & receive)

Router Functions

- Single User Router Mode (Modem mode):
NAT disabled, with option to enable/disable DHCP
- Multi-User Router Mode:
NAT enabled, with option to enable/disable DHCP

Interfaces

- 2 x RJ45 Ethernet ports (one is Power over Ethernet (PoE) port)
- 1 x Primary Handset connector
- 1 x GPS output connector (NMEA-0183, Offset latch RJ11)
- WLAN 802.11b/g build in
- 1 x Antenna Connector:
 - Transceiver Unit: TNC female
 - Antenna Unit: TNC female
- 2 x Standard phone port (RJ11) for FAX and phone
- 1 x SIM Card Slot
- 3 x Status indicator LED
- 1 x Power On/Off Switch
- 1 x DC Power Input socket
- 1 x Ground stud connector
- 1 x GPIO signal port connector
 - 1 x Transmitter On/Off
 - 1 x ignition On/Off
 - 1 x Buzzer
 - 1 x Illuminate Remote On/Off
- 1 x Safe Mode switch
- 1 x Circuit breaker reset switch

Power Supply

- DC input: +12V/24V (+10.8V to +32V)
- Power: (Max) 60W

Physical Data

- Dimension
 - Transceiver Unit: 340 x 253 x 61.5mm, 13.4 x 10.0 x 2.4 in
 - Antenna Unit: 252mm (Dia) x 119.12mm (H), 9.9 in (Dia) x 4.7 in (H)
- Weight
 - Transceiver Unit: 3.5kg / 7.7lbs
 - Antenna Unit: 1.9kg / 4.2lbs

Environmental Conditions

Transceiver Unit

- Operating Temperature: -25°C to +55°C
- Storage Temperature: -40°C to +80°C
- Operating Humidity: 95% non-condensing at +40°C
- Ingress Protection: IP44

Antenna Unit

- Operating Temperature: -25°C to +55°C
- Storage Temperature: -40°C to +80°C
- Operating humidity: 95% non-condensing at +40°C
- Ingress protection: IP56
- Turning Rate: 60deg/second
- Turning acceleration: 50deg/second²

Primary Handset

- Display: 2inches, 65K color, 220 x 176 pixel, 2" TFT Liquid Crystal Display
- Dimension: 142 x 56 x 22mm, 5.6 x 2.2 x 0.9 in
- Weight: 390g/0.8lbs
- Operational Temperature: -20°C to +55°C
- Storage Temperature: -30°C to 70°C
- Ingress protection: IP66

Feature Highlights of Primary Handset

- Configuration setting
- Basic circuit switched telephone functions
- Phone book retrieval from the SIM card
- Call Log for most recent 5 missed, received and dialed calls with date and time stamps
- Short Message Services (SMS)
- User friendly Menu driven graphical user interface
- Hands free Headset

2 Using the Primary Handset

The Primary Handset

The Primary Handset is connected to the Transceiver Unit using the dedicated **HANDSET** port and is powered directly from the TU. Equipped with a large 2', 65K CSTN, 220 Liquid Crystal Display (LCD), Primary Handset not only acts as a standard phone that allows you to make/ receive voice calls, it also serves as a remote access TE (Transceiver Equipment) for you to access various configurations supported by the TU.

Primary Handset offers the following features:

- ✓ Making standard CS voice calls
- ✓ Making standard/streaming PS background data connections
- ✓ Messaging (SMS)
- ✓ User contacts (combined SIM and TU storage)
- ✓ Speed dial
- ✓ Call logs
- ✓ Managing TU security settings
- ✓ Accessing TU settings that includes:
 - Ethernet
 - Cipherring control
 - Satellite selection
 - Supplementary services
 - Transceiver restart
 - Limited factory reset
- ✓ Displaying various TU status and information
- ✓ Local handset configurations



Powering Up the Primary Handset

The Primary Handset is automatically powered up once it is connected to the dedicated **HANDSET** port. Depending on the conditions of the TU, the Primary Handset may start in the following modes:

Full functioning mode

Primary Handset starts in this mode once it has successfully connected to the TU and there is no PIN authentication required. All TU settings including contacts, messages and call logs are loaded into local memory of the Primary Handset once the TU is configured. You will be able to access all the menus and making voice or data calls once the Primary Handset is ready.



PIN mode

Primary Handset starts in this mode once it has successfully connected to the TU and PIN authentication is required. Depending on the enabled PIN, you are required to enter the correct PIN/password before proceeding to **Full functioning mode**. Refer to **Security settings** menu for more information on the types of security PIN in the TU.

To enter the PIN:

1. Key in the PIN of the security key using the alpha-numeric keypad.
2. Press  key to confirm.

To cancel PIN entering:

1. Press the Right  selection key
2. Confirm to start in Emergency only mode by pressing the  key.

Emergency only mode

Primary Handset starts in this mode once it has successfully connected to the TU and PIN entering is bypassed (i.e. when you have forgotten the required PIN). You can only make emergency calls or access local **Phone manager** menu in this mode.



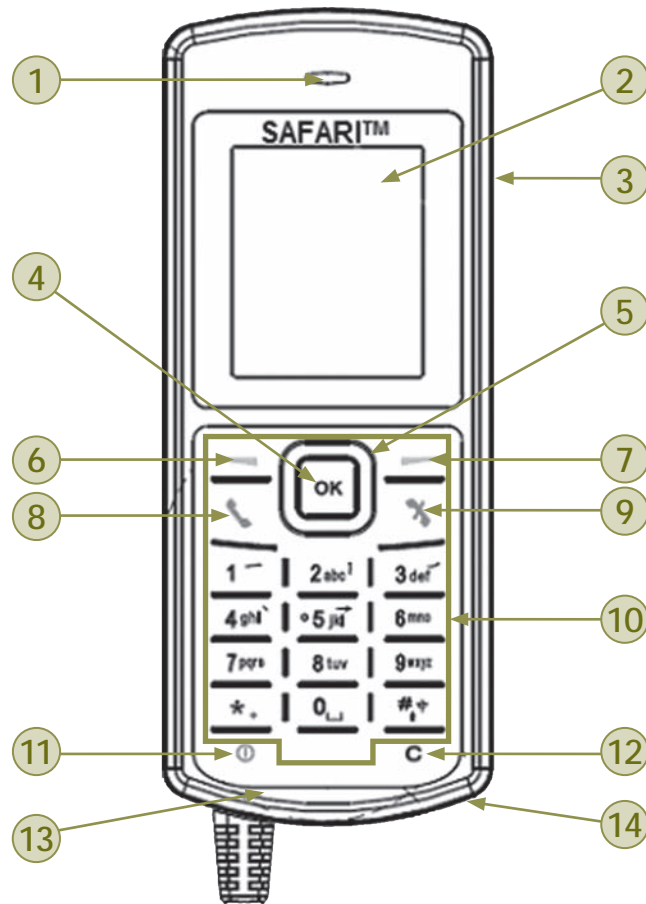



Primary Handset Keypad



1. Earpiece
2. Display
3. Ear-set jack
4. OK key
5. 4-way navigation ring
6. Select key (Left)
7. Select key (Right)
8. Call/Answer key
9. Call/Menu End key
10. Keypad (Alpha-numeric)
11. Power key
12. Clear key
13. Microphone
14. Service Port
15. Ringer*

*The Ringer is located at the back of the Primary Handset.

Keypad - Description and Functions

Keys	Description/Functions
	<p>4-way navigation ring.</p> <p>Press the 4-way navigation ring to scroll left, right, up, and down on the display. Enables scrolling through names, phone numbers, menus or settings.</p>
	<p>OK key.</p> <p>Pressing this key selects/confirms the function highlighted on the display.</p>
	<p>Left selection key.</p> <p>The function of this key depends on the guiding text shown on the display above the key.</p>
	<p>Right selection key.</p> <p>The function of this key depends on the guiding text shown on the display above the key.</p>
	<p>Call/Answer key.</p> <p>After entering a phone number: Initiates a call to the number.</p> <p>From Main Display screen: Opens a list of dialed calls.</p> <p>When Ringing: Answers the incoming call.</p>
	<p>Call/Menu End key.</p> <p>Press this key to end active calls or exits from any menus or sub menus.</p>
	<p>Keypad.</p> <p>Used to enter numbers and characters. Press 0 to add a space when writing text.</p> <p>The functions available depend on whether you are typing a phone number (number mode) or text (text mode).</p>

Keys	Description/Functions
* +	<p>Star * key.</p> <p>When entering a phone number, press this key to insert a *. Press and hold this key to insert a +.</p> <p>When writing text, press this key to access a list of special symbols.</p>
# 中 ↑	<p>Hash # key.</p> <p>When entering a phone number, press this key to insert a # .</p> <p>To quickly change the text input method when writing text, press this key repeatedly and check the indicator at the top of the display</p> <p>In standby mode, press and hold this key to set the Primary Handset into silent mode.</p>
ⓘ	<p>Power key.</p> <p>Press and hold this key to power on/off the TU and Primary Handset when the power button is enabled.</p>
C	<p>Clear text.</p> <p>Press key once to clear one character at a time or press and hold this key to clear the whole text entry.</p>



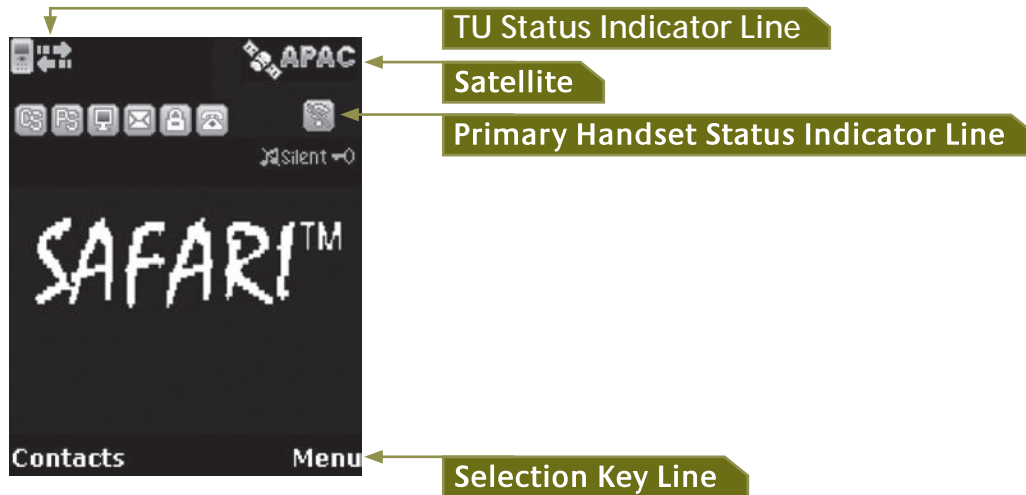











The Main Display Screen



- **TU Status Indicator line**
The indicator line shows status symbol informing you about the operating conditions of the TU.
- **Satellite**
The indicator line shows status symbol informing you about the satellite service.
- **Handset Status Indicator line**
The indicator line shows status symbols informing you about the operating conditions of the Primary Handset.
- **Selection Key line**
The Selection key line operates using the Left ◀ or Right ▶ selection keys with  to access menus and controls.

Primary Handset Status Indicators



Table below explains the meaning of each status indicator displayed in the Main Display screen.

Status Indicator	Description
	New short message (SMS) in inbox
	Available PS domain services
	Available CS domain services
	Data connection is inactive (available in Manage profiles sub menu only)
	Data connection is active
	Ciphering enabled
	Radio silent is active
	Primary Handset keypad lock is active
	Primary Handset disconnected from TU
	Primary Handset connected to TU
	The terminal has locked on to Inmarsat satellite "I-4 Asia Pacific"
	The terminal has locked on to Inmarsat satellite "I-4 EMEA"
	The terminal has locked on to Inmarsat satellite "I-4 Americas"
	Primary Handset in silent mode
	Telephony CS port is engaged



Making a Voice Call

Note:

Before making a voice call, please make sure that:

- The Primary Handset is connected to the TU ( status indicator should be on)
- The Primary Handset is NOT radio silent( status indicator should be off)
- The TU has successfully registered with the network and ready for CS domain (voice) services ( status indicator should be on)

You can use the following two options for making a call:

- **Manual Dial**
 1. Using the alphanumeric keypad, dial **00 <country code> <phone number>**.
 2. Press  key.
- **Using Contacts or Call Log list from the Primary Handset.**
 - Enter the **Contacts** list of the Primary Handset, scroll to the desired number and press  key, or
 - Enter the **Log** list of the Primary Handset, scroll to the desired number and press  key.

Note:

For voice calls and SMS, you may also use '+' by pressing and holding the *+ key instead of "00" at the beginning of dialed number string as an alternative ('+ <country code> <phone number>').

To End a Call

1. Press .

Receiving a call

When there is an incoming call, the Primary Handset will:

- Ring.
- The caller's number will be displayed on the screen.
If the number is stored in the contacts, the corresponding name of contact will be displayed.

To answer an incoming call, press the  key.

Adjusting volume during a call

Use the 4-way navigation ring  to adjust the volume.



Using the Menus

You can access the Menu System by pressing the Right  selection key in the Main Display screen.

The main menu of the Primary Handset includes nine (9) menu options with each menu option having their respective sub-menus.













You can use the 4-way navigation  ring to navigate to the desired menu option and press  to confirm your selection. You can also end the menu or sub menus and return to the Main Display screen at any time by pressing the  key.

Table below summarizes the functionalities within each menu option:

	Contacts This menu manages your user contacts.
	Log This menu allows you to view call histories.
	Telephony This menu configures settings related to CS voice telephony services.
	Data This menu configures settings or connections related to PS data services.
	Messaging This is menu is for SMS related services.
	Settings This menu configures general TU settings.
	Transceiver This menu displays general TU information.
	Security settings This menu configures security settings related to the TU.
	Phone manager This menu configures local handset settings.



Contacts Menu

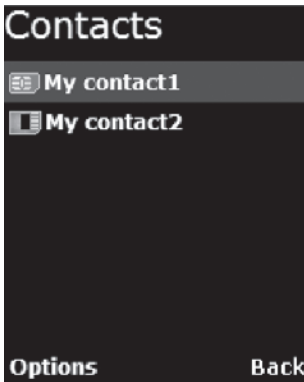

The **Contacts** menu allows you to store, retrieve and update names and phone numbers of your contacts in the Primary Handset memory and in the SIM card memory. You can also access this menu by pressing Left selection key in Main Display screen.

This menu lists all the contacts saved in both the TU and SIM card memory where,

Indicates contacts that are saved in TU and

Indicates contacts that are save in SIM card.

The following options are available when pressing the Left selection key while browsing through the contacts:

- **New contact**

Add new contact to the memory. To add contact:

1. Select **New contact**.
2. Select where you want to store the contact (Terminal or SIM).
3. Enter the name for the contact.

Note: Press *+ key to browse for symbols.

4. Enter the number for the contact.

Note: Stored number can be in any one of the following formats:

- '+> <country code> <phone number>
- 00 <country code> <phone number>

Press *+ key to insert '+' sign.

Saving of contact without number is not allowed.

5. Select **Save** (Left selection key) or pressing the key to save the contact to the selected memory.

Note:

Refer to “Tips for writing the text” section under *New message* for more information on text writing.

- **Search**

Select this to enter a specific name to search within the contact list.

- **Delete**

Delete selected contact.

Note:

You can also delete the selected contact by pressing the Clear **C** key.

- **Copy**
Select this to copy the selected contact from SIM card memory to TU memory or vice versa.
- **View number**
Display the number of the selected contact.
- **Assign Speed Dial**
Add the selected contact to the speed dial list.
- **Reload Contacts**
Select this to reload contacts from the TU/SIM card into the local memory of the Primary Handset.
- **Memory Status**
Select this to view the memory status of the contacts.

While browsing through the contact list, press the  key to view the phone name and number or the selected contact. The following options are available when pressing the Left  selection key while viewing the selected contact:

- **Call**
Make a voice call to this contact.
- **Send message**
Open a SMS editor to send a text message to this contact.
- **Edit contact**
Edit information of this contact.
- **Delete**
Delete this contact.
- **Copy**
Select this to copy this contact from SIM card memory to TU memory or vice versa.
- **Forward contact**
Forward information of this contact using SMS.
- **Assign Speed Dial**
Add this contact to the speed dial list.

Note:

You can also make a voice call to the selected contact when browsing through or viewing the contacts by pressing the Call  key.



Log Menu

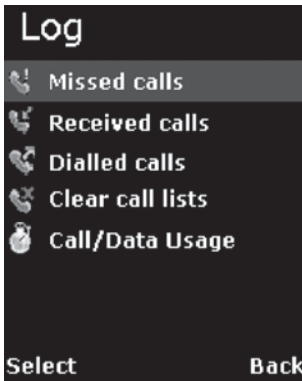

The **Log** menu allows you to view historical information about phone calls and data usage in chronological order with the following sub menus:



Missed calls

Received calls

Dialed calls

Call history of the particular category is displayed in chronological order when selected. Up to 5 latest entries of each category can be saved.

The following options are available when pressing the Left  selection key while browsing through or viewing the call log:

- **Delete**
Delete the selected log entry from the list.

Note:
You can also delete the entry by pressing the Clear C key.
- **Call**
Call the number in the selected log entry.
- **Send**
Send an SMS to the number in the selected log entry.
- **Save**
Save the number from the selected log entry to the contact list.

Note:
This option is not available when the log entry already has an entry in the contact list.

Note:

You can also make a voice call to the number of the selected log entry when browsing through or viewing the call log by pressing the Call  key.



Clear call lists

Select this to clear the call log entries. Available log options are:

- **Missed calls**
- **Received calls**
- **Dialled calls**
- **All calls**

Delete all logs including **Missed, Received** and **Dialled logs**.



Call/Data usage

Display the accumulated call and data duration. Press Left  selection key to clear the call or data duration.



Telephony Menu

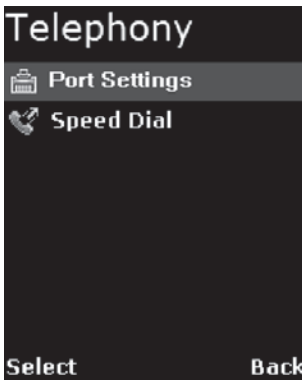

The **Telephony** menu allows you to configure telephony related settings with the following sub menus:



Port Settings

- **Primary Handset**
Contain options for incoming and outgoing call types.
Select this to configure the call type settings. The following options are available when pressing the Left ◀ selection key while browsing through the list:
 - Standard
 - NONE
- **Phone Port**
Contain options for incoming and outgoing call types.
Select this to configure the call type settings. The following options is available when pressing the Left ◀ selection key while browsing through the list:
 - Standard
 - High quality [fact: only applicable if fax is purchased]
 - BOTH (only for incoming) [fact: only applicable if purchase fax]
 - NONE
- **Fax (OPT) Port**
Contain options for incoming and outgoing call types.
Select this to configure the fax type settings. The following options is available when pressing the Left ◀ selection key while browsing through the list:
 - High quality [fact: only applicable if purchase fax]
 - NONE



Speed dial

- **Setting**
Contain options to enable/disable the speed dial feature.
- **Speed Dial List**
Select this to configure the speed dial list. The following options are available when pressing the Left selection key while browsing through the list:
- **Assign**
Assign a contact to the selected entry. To assign a contact:
 1. Select Speed Dial List.
 2. Browse through the list to locate an empty entry.
 3. Select Options by pressing Left selection key.
 4. Select Assign and press from the option.
 5. Select the desired contact to assign to the speed dial list.
 6. Press to confirm your selection.
- **Delete**
Remove contact from the selected entry. This option is not available for empty entry.

Note:
You can also delete the entry by pressing the Clear key.
- **Call**
Make call using the number from the selected entry. This option is not available for empty entry.

Note:
You can also make a voice call to the number of the selected entry by pressing the Call key.

You can make a voice call directly from the Main Display screen by pressing the corresponding speed dial entry number + Call key once the speed dial feature is enabled with a valid contact entry.



Data Menu

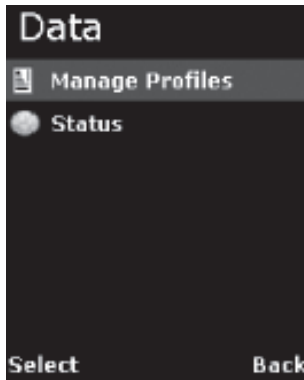

The **Data** menu provides the following sub menus to manage and configure data connections (PDP profiles) for the TU:



Manage profiles

Allow you to manage the Primary and Secondary PDP profiles.

- Primary profiles
One **Standard** Primary PDP profile has been created in the Primary profile list as a default profile. The profiles listed in the list are:
 - Standard
 - 32k Streaming
 - 64k Streaming
 - 128k Streaming

You can press the Left ◀ selection key for options available when browsing through the profile list. The list of options is:

- **Edit**
Edit the selected profile.
- **Delete**
Delete the selected profile.
- **Add**
Add new profile into the list.
- **Reset table**
Reset profile list. All profiles will be deleted and a default profile is created.

➤ Adding/Editing profiles

You can press the Left ◀ selection or  key from the option list to add new or edit existing profile settings.

- **Profile name**

Specify the name of the profile.

- **Connection type**

Both **Standard** and **Streaming** connection types are supported.

- **APN**

Specify information of the APN (Access Point Name). Further available settings are:

APN: Specify the Access Point Name for the connection. Default APN is according to SIM card. Enter your own APN if you do not want to use the default APN from the SIM card.

Username: Specify the user name for **Static** IP configuration. Default is blank for **Dynamic** IP configuration.

Password: Specify the password for **Static** IP configuration. Default is blank for **Dynamic** IP configuration.

You can press the Left ◀ selection key for the following options:

- **Edit**

Edit the selected APN setting.

- **Fetch from SIM**

Fetch the APN from the SIM card. This option is only available when APN is highlighted.

- **IP configuration**

Contain options for **Static** or **Dynamic** IP. Default is **Dynamic** IP configuration.

- **IP address**

Specify the IP address for **Static** IP configuration. This field is ignored for **Dynamic** IP configuration. Default is blank for **Dynamic** IP configuration.

- **Header comp.**

Contain options to enable or disable header compression. Default is **Enabled**.

Note:

For 32k, 64k and 128k Streaming profiles, there are three additional options when selecting editing their settings. The additional options are:

- **Desired rate**
Choose the desired rate for the different profiles. Note that the default setting for each profile is the profile chosen. For example, for 32k Streaming, the default rate is 32k.
- **Minimum rate**
Choose the minimum rate for the different profiles. Note that the default setting for each profile is the profile chosen. For example, for 32k Streaming, the default rate is 32k.
- **Error correction**
Contain options to enable or disable error correction. Default is disabled.

- **Secondary Profiles**

The profiles listed in the list are:

- **FTP**
- **Quick Link**
- **Quick Time Media**
- **Real Media**
- **Stream Box**
- **Win Media**

- **Adding/Editing profiles**

You can press the Left  selection or  key from the option list to add new or edit existing profile settings.



- **Profile name**
Specify the name of the profile.
- **TFT**
Choose desire type of connection.
- **Desired rate**
Choose the desired rate for the profile. Default settings for all secondary profiles are set as 32K.
- **Minimum rate**
Choose the minimum rate for the profile. Default settings for all secondary profiles are set as 32K.

- **Error correction**

Contain options to enable or disable error correction. Default is Disabled.

Note:

You will be prompted to save the changed settings before exiting the sub menu. Press Left ◀ selection key or  key to save the changes.

Icon  in the profile list indicates that the profile is not active and icon  indicates that the profile is currently active in use.



Status

Allow you to check the status of the data connection. You can also activate/ de-active a specific profile in the status display list.

Note:

You will not be able to enter this sub menu if the TU has not been registered for PS data service.

The status list shows you the current active data connection. Depending on whether there is an active connection, you can press the Left ◀ selection key for the following options:



- **Activate primary**

This option is available when there is no active data connection. Select this to choose from the profile list for activation.

- **Deactivate**

This option allows you to de-active an active data connection.



To active a primary data connection when there is no active connection:

1. From the data status list, select Options using the Left ◀ selection key.
2. Select **Activate primary** using Left ◀ selection key or  key.
3. Select from a list of configured primary profile for activation. Press Left ◀ selection key or  key to confirm.
4. You are prompted to confirm activation. Confirm activation by selecting **Yes** using the Left ◀ selection key or  key.

Note:

It may take a while to active a data connection.

To de-active a primary data connection when there is an active connection:

1. From the data status list, select Options using the Left ◀ selection key.
2. Select **Deactivate** using Left ◀ selection key or  key.
3. You are prompted to confirm de-activation. Confirm de-activation by selecting **Yes** using the Left ◀ selection key or  key.



Messaging Menu

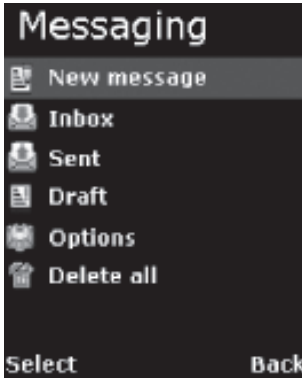





The **Messaging** menu allows the user to write a new messages, view stored messages from **Inbox**, **Drafts** and/or **Sent** folders and configure settings related to SMS with the following sub menus:



New Message

Select this to create and send a new message. To create new message:

1. Select **New Message** by pressing the  key. A SMS editor will be displayed on the Primary Handset screen for writing new message.
2. Type in your SMS message using the alpha-numeric keypad.
3. To send the message, press the  key and select **Send**.
4. Enter the recipient's phone number, and press the  key. Alternatively you can select **Search** by pressing the Left  selection key to select the phone number from the contacts.

Options:



You can press the Left  selection key to select options available when writing the message.

- **Send**
Select this when you are ready to send your message.
- **Save**
Select this to save the message into the **draft** folder.
- **Clear screen**
Select this to clear all the written text.

Tips for writing the text:

- Press the **0** key to add a space.
- To quickly change the text input mode when writing text, press **#*#** key repeatedly and check the indicator at the top of the display:
 - **<ABC >**: Capital letters
 - **<123>**: Numbers
 - **<abc>**: Small letters
 - **<Abc>**: Initial Capital letter followed by small letters
- To add a number in alphabet mode, press and hold the desired number key.

Inserting symbols to your message:

- To get a list of special symbols, press the ***. .** key.
- Using the 4-way navigation ring , navigate to the desired symbol.
- Press  to confirm selection.

Clearing text:

- To clear text, press **C** once to clear one character at a time.
- To clear the whole text entry, press and hold **C** to clear the whole text entry.

Inbox

Contain new/opened text messages that you have received. When browsing through the messages list using the 4-way navigation  ring,



Indicates an unread (new) message and
Indicates read (opened) text messages.

The following are available options when pressing the Left  selection key while browsing through or viewing the messages in this folder:

- **Open**
Open selected message. You can also press  while browsing through the message list to open the selected message (This option is not available when viewing the message).
- **Reply**
Select this to reply to the selected message sender.
- **Delete**
Delete selected message.

Note:

You can also delete the selected message by pressing the Clear **C** key.

- **Forward**
Forward this message to another recipient.
- **Call**
Make a voice call to the selected message sender.
- **Save**
Save the selected message into the Draft folder.
- **Details**
Display the details of the selected message.
- **Add to contact**
Select this to add the phone number of the selected message into the contact list.

Note:

You can also make a voice call to the selected message contact when browsing through the messages list by pressing the Call  key.



Sent

Contain text messages that you have sent. The following are available options when pressing the Left  selection key while browsing through or viewing the messages in this folder:

- **Open**
Open selected message. You can also press  while browsing through the message list to open the selected message (This option is not available when viewing the message).
- **Delete**
Delete selected message.

Note:

You can also delete the selected message by pressing the Clear **C** key.

- **Send**
Send the selected message to another recipient.
- **Save**
Save the selected message into the Draft folder.

- **Add to contact**

Select this to add the phone number of the selected message into the contact list.

Note:

You can also make a voice call to the selected message contact when browsing through the message list by pressing the Call  key.



Draft

Contain text messages that you have saved. The following are available options when pressing the Left  selection key while browsing through or viewing the messages in this folder:

- **Open**

Open selected message. You can also press  while browsing through the message list to open the selected message (This option is not available when viewing the message).

- **Delete**

Delete selected message.

Note:

You can also delete the selected message by pressing the Clear **C key.**

- **Send**

Send this message to another recipient.

- **Save**

Save the selected message into the Draft folder.

- **Add to contact**

Select this to add the phone number of the selected message into the contact list.

Note:

You can also make a voice call to the selected message contact when browsing through the message list by pressing the Call  key.



Options

The following settings are available in this sub menu:

- **Message Centre**
Select this to set the number of the SMS service center.
- **Save sent message**
Select this to enable or disable the saving of sent messages. When this option is enabled, all successfully sent messages are saved in the **Sent** folder.
- **Memory status**
Select this to view the memory status of the messages.
- **Reload Messages**
Select this to reload messages from the TU into the local memory of the Primary Handset.



Delete all

Select this to clear the messages in a particular folder. Available folder options are:

- **All messages**
Delete messages in all folders including **Inbox**, **Sent** and **Draft**.
- **Inbox**
- **Sent**
- **Draft**



Settings Menu

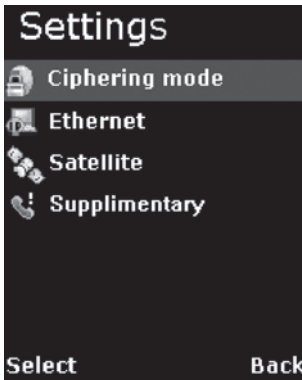

The **Settings** menu provides the following sub menus to configure the TU:



Ciphering mode

Contain options to enable/disable the use of ciphering mode between the network and TU.

Note:

Status icon  is displayed in the Main Display screen when ciphering is enabled.



Ethernet

Allow you to configure settings related to Ethernet connection.



- **Terminal IP Address**
Specify the IP address of the TU. The default IP address of the TU is 192.168.1.35.
- **Subnet Mask**
Specify the subnet mask of the TU. The default subnet mask of the TU is 255.255.255.0.
- **DHCP settings**
Display the status and settings of the DHCP server.
 - **DHCP server**
Display the status of the DHCP server.
 - **Start IP address**
Display the start IP address of the DHCP server. Default start IP address is 192.168.1.40.
 - **End IP address**
Display the end IP address of the DHCP server. Default end IP address is 192.168.1.59.
 - **Primary DNS**
Display primary DNS server address. Default primary server is 172.30.66.7.

- ❑ **Secondary DNS**

Display secondary DNS server address. Default secondary server is 172.30.34.7.

- ❑ **Lease time**

Display the lease time. Default lease time is 60.

Except for **DHCP server**, the rest of the display settings can be edited by pressing the Left  selection or  keys.

Note:

Make sure that the format is correct when entering an IP address. Press the Star * key multiple times to insert the “.” sign.



Satellite

Manage settings related to Inmarsat satellites.

- **Satellite selection**

Allow you to select the preferred satellite to lock on to. Default is AUTO where the TU automatically searches for the best satellite in view to lock on to.

Note:

Satellites visible to the TU are marked with *. The TU will de-register from the network with all the CS (voice) and PS (data) services terminated whenever a new satellite is manually selected from the list. The TU can only re-register with the network once it has successfully locked onto the newly selected satellite.

Satellite status

Display current satellite status. The following information is displayed:

- ❖ **Status**

Display status of the TU. The TU can be either searching or locked on to a particular satellite.

- ❖ **Satellite ID**

Satellite ID that the TU is currently searching for or locked on.

- ❖ **Satellite Name**

Satellite Name that the TU is currently searching for or locked on.



Supplementary

Configure settings related to supplementary services. These settings are applicable to standard CS voice services.

Note:

Depending on the network, some settings may not be available or may prevent other settings from being activated.

The following sub menus are available:

- **Call forwarding**
Allow you to configure for call forwarding services depending on various conditions. The following forwarding conditions are available for configurations:
 - **All Calls**
All calls are unconditionally forwarded.
 - **Busy**
Calls are forwarded when the TU is busy.
 - **No answer**
Calls are forwarded when no answer from the TU for a specific time.
 - **Not reachable**
Calls are forwarded when TU is not reachable.

You can press the Left  selection key for options available when browsing through the list of forwarding conditions. The list of options is:

- **Retrieve all**
Retrieve network settings of all the listed conditions.
- **Update all**
Update configured settings of all the listed conditions to the network.
- **Cancel all**
Deactivate all condition settings.

Note:

Operations on this level affect all forwarding conditions and hence it may take some time to process.

Pressing the  key configures a particular forwarding condition. The following settings can be configured:

Status: Display active or Inactive status of the selected forwarding condition. Press the  key to change the status.

Number: Display number to forward calls to when selected forwarding condition is active. Press the  key to change the number.

Time: Only applicable to No answer forwarding condition. To forward calls to selected number if call no answer for a specific period of time. Press the  key to change the time.

You can press the Left  selection key for options available when configuring a particular forwarding condition. The list of options is:

- **Retrieve**
Retrieve network settings of the selected condition.
- **Update**
Update configured settings to the network for the selected condition.

Note:

Always use Retrieve all or Retrieve options to retrieve the latest settings from the network. Use Update all or Update options to update the network settings after configurations.

- **Call barring**
Allow you to configure for call barring services depending on various barring conditions. The following conditions are available for activations/deactivations by pressing the  key:
 - ❑ **Outgoing calls**
Barring of all outgoing calls.
 - ❑ **Incoming calls**
Barring of all incoming calls.
 - ❑ **Int. except home**
Barring of all outgoing international calls except to home country.
 - ❑ **Incoming if abroad**
Barring of all incoming when roaming.

You can press the Left  selection key for options available when browsing through the list of barring conditions. The list of options is:

- **Retrieve**
Retrieve network settings of the highlighted condition.
- **Retrieve all**
Retrieve network settings of all the listed conditions.
- **Update**
Update configured settings to the network for the highlighted condition.
- **Update all**
Update configured settings of all the listed conditions to the network.
- **Cancel all**
Deactivate all condition settings.

You will be asked to enter the call barring password when updating the settings to the network. Consult your equipment distributor if necessary.

Note:

Always use Retrieve all or Retrieve options to retrieve the latest settings from the network. Use Update all or Update options to update the network settings after configurations.

- **Call waiting**
Contain options to enable/disable call waiting services. You can also press the Left  selection key for the following options:
 - **Retrieve**
Retrieve network settings of the call waiting service.
 - **Update**
Update configured settings to the network.

Note:

Always use Retrieve option to retrieve the latest settings from the network. Use Update option to update the network settings after configurations.

- **Caller ID**
Allow you to configure settings that are related to caller identifications.
 - **Setting**
Contain options to configure for USA or Europe caller ID type.

- **Send Caller ID**

Allow you to enable/disable sending of your caller ID to the recipient when making a call. Default is AUTO where the default network settings are used. You can also press the Left ◀ selection key for the following options:

- **Retrieve**

Retrieve network settings of the call waiting service.

- **Update**

Update configured settings to the network.

Note:

Always use *Retrieve* option to retrieve the latest settings from the network. Use *Update* option to update the network settings after configurations.



Transceiver Menu

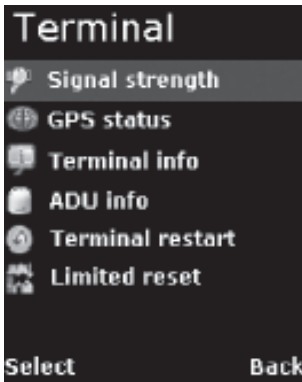



The **Transceiver** menu provides the following sub menus to check for information and perform resets on the TU:



Signal strength

Show graphical representation of current signal strength and GPS type. Table below describes the available GPS type icons used in this sub menu:

	This icon shows that the TU is in the process of acquiring a GPS fix when there is no previously stored GPS fix.
	This icon shows that the TU is using New GPS coordinates.
	This icon shows that the TU is using previously stored GPS coordinates.



GPS status

Show current Latitude and Longitude coordinates, the GPS type and Time of acquisition on the TU.



Terminal Info

Display a list of information of the TU.

- ❖ **Manufacturer**
Manufacturer name of the TU
- ❖ **Software version**
Software version of the TU
- ❖ **Model**
Model name of the TU
- ❖ **IMEI number**
IMEI number of the TU

- ❖ **IMSI number**
IMSI number of the SIM card
- ❖ **Subscriber number**
Subscriber's telephone number
- ❖ **Serial number**
Serial number of the TU



Antenna Unit Info

Display a list of information of the Antenna.

- ❖ **Serial number**
Serial number of the Antenna



Transceiver restart

Soft restarting the TU



Limited reset

Perform limited reset on the TU. Apart from full factory reset that is not available in Primary Handset, limited reset only resets a small portion of the TU settings. Stored GPS status, contacts, call logs and event logs are not cleared during limited reset.

You are also required to key in the password when performing the reset. The default password is 0000.

Note:

This password is the same as Transceiver PIN.



Security settings Menu

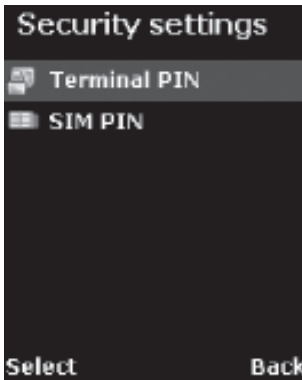

The **Security Settings** menu provides the following sub menus to configure the security settings of the TU using different PIN:



Terminal PIN

SIM PIN

There are three options available for selection under each sub menus to manage the PIN and security settings for the TU:

- **Enable**

Enable the selected PIN. Table below summarizes the default PIN codes for each security setting:

Terminal PIN	0000 Note: Terminal PIN is the same PIN that has to be entered when performing Limited Reset on the TU.
SIM PIN	Depends on your SIM card. Consult your equipment distributor if necessary. Note: You have to enter the PUK (PIN Unblocking Key) to access the SIM card if a wrong PIN for SIM PIN has been entered for three times. You will be asked to enter the new PIN code once you have entered the correct PUK. However, the SIM card is no longer usable if you have entered wrong PUK for 10 times.

You will be asked to key in the existing PIN (or default PIN if it has not been changed) before the PIN can be enabled

- **Disable**
Disable the selected PIN. You will be asked to key in the existing PIN (or default PIN if it has not been changed) before the PIN can be disabled.
- **Change**
Change the PIN to a new one. You will be asked to key in the existing PIN (or default PIN if it has not been changed) before the PIN can be changed.

Note:

PIN has to be enabled before it can be changed.



Phone manager Menu



The **Phone manager** menu provides the following sub menus to configure settings that are local to the Primary Handset:



Display

Configure settings that are related to Primary Handset display.

- **Backlight**

Used to set the duration of the display backlight to remain on. Settings range from Always On (Backlight permanently on), 15 seconds to 1 minute.

Note:

The backlight will be slightly dimmer and finally off when there is no keypad activity after sometime. However, this feature is not available when the setting is set to Always On).



Tone

Configure tone setting for the standard and ring tones.

- **Standard tone**

- **Keytone**

Contain options to enable/disable the key tone.

- **Message tone**

Contain options to enable/disable the message tone.

- **Volume**

Configure the volume for the standard tones (both key and message tones). Using the 4-way navigation ring (OK), press up/right to increase and down/left to decrease the volume.

- **Ring tone**

- **Tone**

- Select desired ring tone pattern.

- **Volume**

- Configure the volume of the ring tone. Using the 4-way navigation ring , press up/right to increase and down/left to decrease the volume.



Language

Allow you to change the menu display language.



Factory settings

Allow you to configure default factory settings of the Primary Handset. Contains the following settings:

- **Power button**

- Provide options to enable/disable the power button. You can press the Power  key to power on/off the TU and Primary Handset once the power button is enabled.

- **Factory reset**

- Perform factory reset on the Primary Handset.



About

Display a list of information of the Primary Handset.

- ❖ **Model**

- Model name of the Primary Handset

- ❖ **Software version**

- Software version of the Primary Handset

- ❖ **Hardware version**

- Hardware version of the Primary Handset

- ❖ **Technical support**

- Web address for technical support

- ❖ **Copyright**

- Contain Copyright message

3 Using the Web Console

1. Connect your computer to the SAFARI™ TU using a LAN cable.
2. When the connection has been established, open the web browser.
3. Type **http://192.168.1.35** in the **Address** field and press **Enter**.



The Login screen appears.

4. Type in **admin** in the Username field and **1234** in the password field. Click **Login**.

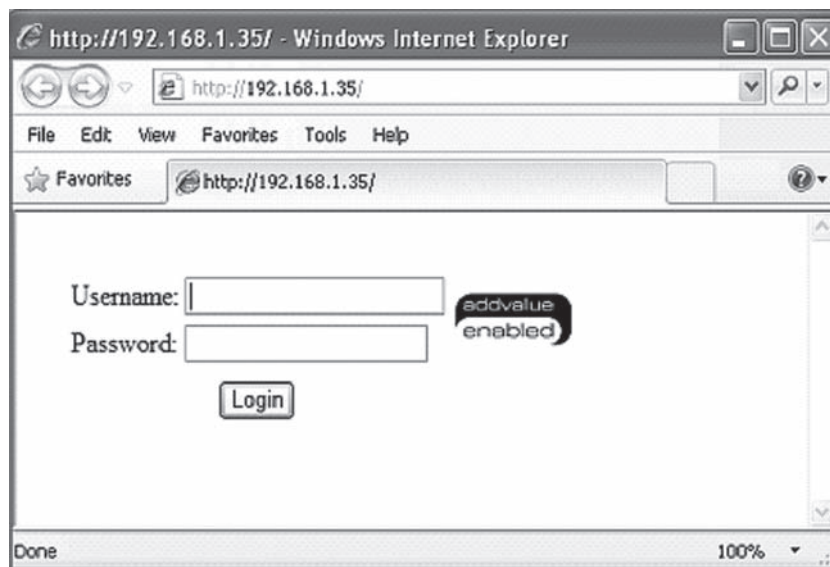

5. The **SAFARI™ TU Web Console** will appear on your screen.

The SAFARI™ TU will automatically register to the network. This process will include GPS acquisition, satellite tracking and registration with the network, which will take a few minutes. Once the process is completed, you will see the following message appearing at the bottom line of the Web Console.

“Registered to Network but no active data connection exists. You are now able to make phone calls and send SMS. Please activate a data connection before doing any data transfer”



Terminal Info Satellite Selection

Signal: 55.5 dBHz

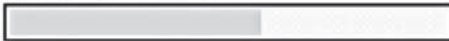

Temperature:
Normal

GPS:
 Latitude: 1° 20' 5.85" N
 Longitude: 103° 53' 22.48" E
 Type: 3D (NEW)
 Time: 11/06/02,09:50:15 GMT

Pointing Angle (Visible Satellites):

I-4 Asia-Pacific	Azimuth:	91.6° E
	Elevation:	44.13°
I-4 EMEA	Azimuth:	269.73° W
	Elevation:	2.41°

Menu Overview



Setup	Phone	SMS	Data	Settings
Terminal Info	Phonebook	Compose	Connection	Language
Satellite Selection	Call History	Inbox	Primary Profiles	Terminal Info
		Sent	Secondary Profiles	Ethernet
		Draft	Port Forwarding	Telephony
			Settings	PIN
				SMS
				Admin
				Support
				Accounts
				About

Status/Action Icons



Note:

Clicking on these icons gives you a shortcut to the desired menu.

- **Orange** indicates the item is active.
- **Grey** indicates the item is inactive.

These icons indicate the status of SAFARI™ TU.

• Status Icons



Logout icon: User can log out from the web console.



CS icon: Indicates the Circuit Switch service status (Voice calls, SMS, FAX).



PS icon: Indicates the Packet Switch service status (Internet Browsing, FTP, email).



GPS icon: Indicates if a new GPS fix is available or not.

• Action cum Status Icons



Internet icon: Orange icon indicates an active data connection. Click on this icon to activate or deactivate data connection (to browse Internet, FTP, email).



Ciphering icon: Orange icon shows that ciphering is enabled. Click on this icon to enable or disable ciphering.



Radio silence icon: Indicates if radio silence is enabled or disabled.



Setup Menu

Viewing Terminal Information



1. Click **Setup**.
2. Click **Terminal Info** to view the SAFARI™ TU Terminal information. The terminal information related to Signal strength, Temperature, GPS Status, Elevation angle and Registration status are displayed on this page.

The screenshot shows the SAFARI™ WEB CONSOLE interface. At the top, there are logos for SAFARI™ WEB CONSOLE, inmarsat, and wideye™ liberating communications. Below the logos are navigation icons for Setup, Phone, SMS, Data, and Settings. The main content area has two tabs: "Terminal Info" (selected) and "Satellite Selection".

Signal: 56.5 dBHz

Temperature: Normal

GPS:
 Latitude: 1° 20' 5.85" N
 Longitude: 103° 53' 21.15" E
 Type: 2D (NEW)
 Time: 11/05/09,06:11:42 GMT

Pointing Angle (Visible Satellites):

I-4 Asia-Pacific	Azimuth:	91.6° E
	Elevation:	44.13°
I-4 EMEA	Azimuth:	269.73° W
	Elevation:	2.41°

Registered to Network but no active data connection exists. You are now able to make phone calls and send SMS. Please activate a data connection before doing any data transfer.

Signal	Indicates the received signal strength (C/No in dB Hz)
Temperature	Indicates the TU's current operating temperature status
GPS	Indicates the latitude, longitude, type and time of the GPS acquisition
Pointing Angle	Indicates the azimuth and elevation angle of the antenna with the corresponding satellite in view

Satellite Selection

The default Satellite Selection is in **Auto** mode. In **Auto** mode, the TU will scan all the visible satellites and track the satellite with the most optimum elevation angle or the last used satellite.

Note: Changing the satellite selection will terminate any existing active voice/fax call or data connections.

Follow these steps to change your satellite selection:

1. Click  .
2. Click **Satellite Selection** to view the visible satellites.
The visible satellites will be displayed for your selection.
It also displays the satellite information that your Antenna Unit's is locked on to.

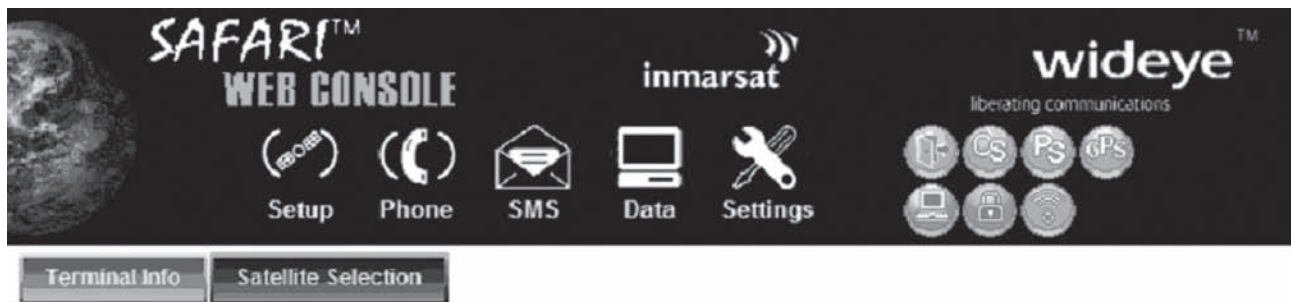

3. Click on your choice of visible satellites.
4. Click **Select** to point the antenna to the selected satellite in exclusive mode.

The satellite selection will be saved and each time you powered up the TU, the satellite selection choice will remain until you make the next selection change. The TU will track the newly selected satellite even if the elevation angle is not optimum.

- Click **Refresh** to refresh the Satellite list.



Phone Menu

Phone menu provide the following options:

- **Phonebook**
Allow you to view, add, edit and delete entries on your Phonebook list. You can make and send SMS messages directly from your Phonebook entries. The Phonebook entries can be stored on the SIM card or the SAFARI™ TU.
- **Call History**
To check on the history log of calls made and received.

The screenshot shows the SAFARI™ WEB CONSOLE interface. At the top, there are logos for SAFARI™ WEB CONSOLE, inmarsat, and wideye™ liberating communications. Below the logos are icons for Setup, Phone, SMS, Data, and Settings. The Phone menu is selected, and the Call History tab is active. The Call History table shows a list of calls with columns for Phone no. and Time. Below the table are buttons for Send SMS, Delete, and Refresh.

Phone no.	Time
006591468876	11/05/26 09:44:12
006591468876	11/05/26 09:43:39
006591468876	11/05/26 09:42:57
006591468876	11/05/26 07:52:41
006591468876	11/05/26 07:47:08

Phonebook

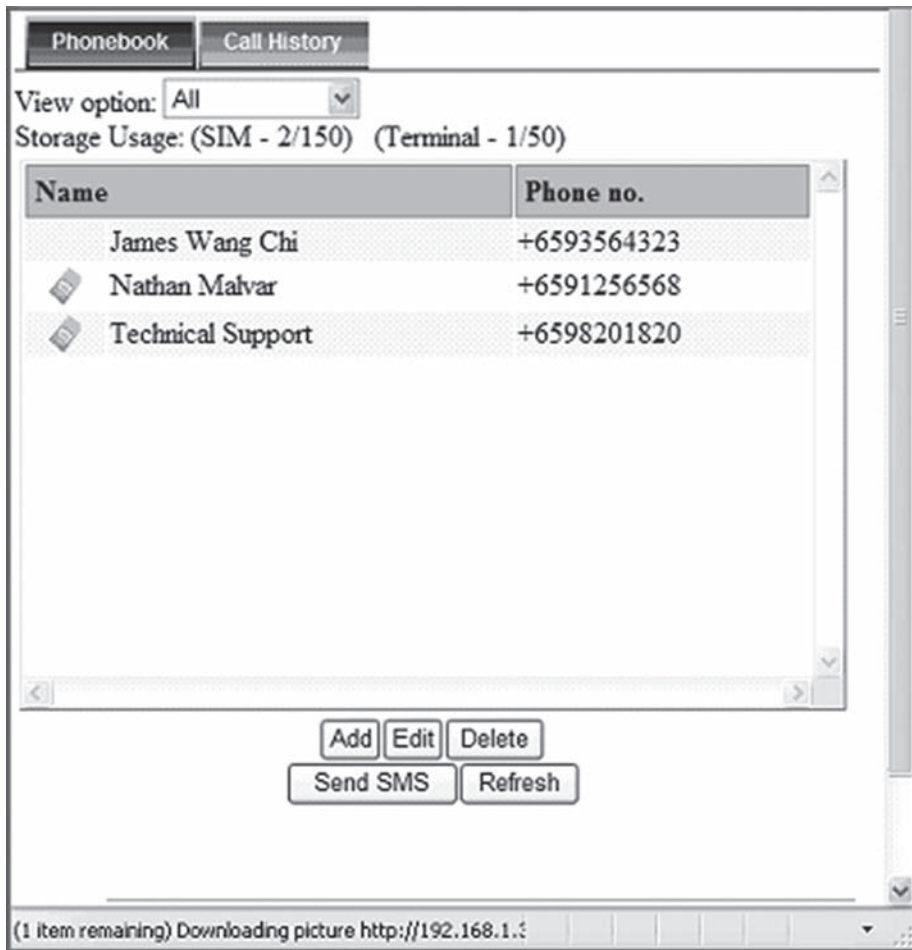

- **View option**

The View option allows you to view the Phonebook entries from the different storage locations.

From the drop-down menu, select:

All	To view the entries stored in the SIM card and SAFARI™ TU.
Sim only	To view the entries stored in the SIM card.
Transceiver only	To view the entries stored in the SAFARI™ TU.

- **Storage Usage**

Shows the number for Phonebook entries used in the SIM card and TU locations.

For example: **(SIM -2/150)** indicates:
Storage location – **SIM** card
Total number of entries used = **2**
Total number of entries available = **150**

Adding a new Phonebook entry

Follow these steps to add a new Phonebook entry:

1. Click **Add**.
2. Enter the Name and Phone number.
3. Select the storage location and click **Save**.

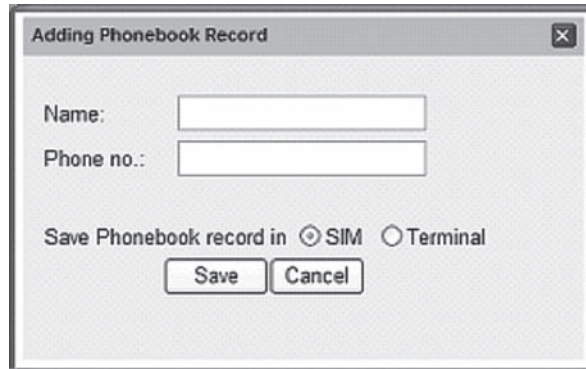

The screenshot shows a dialog box titled "Adding Phonebook Record" with a close button (X) in the top right corner. It contains two text input fields: "Name:" and "Phone no.:". Below the fields, there are two radio buttons: "SIM" (which is selected) and "Terminal". At the bottom of the dialog, there are two buttons: "Save" and "Cancel".

Editing a Phonebook entry

Follow these steps to edit a Phonebook entry:

1. Select the entry from the Phonebook list.
2. Click **Edit**.
3. Proceed to change the Name and/or Phone number.
4. Click **Apply**.

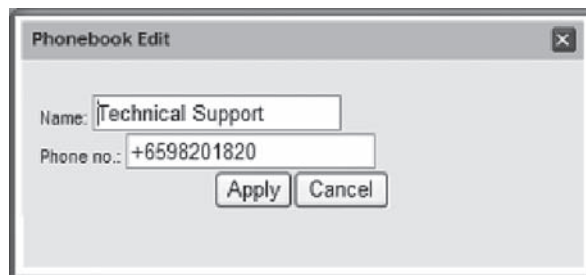

The screenshot shows a dialog box titled "Phonebook Edit" with a close button (X) in the top right corner. It contains two text input fields: "Name:" with the text "Technical Support" and "Phone no.:" with the text "+6598201820". Below the fields, there are two buttons: "Apply" and "Cancel".

Deleting a Phonebook entry

Follow these steps to delete a Phonebook entry:

1. Select the entry from the Phonebook list.
2. Click **Delete**.
3. Click **Ok** to confirm to delete the entry. Click **Cancel** to abort delete.

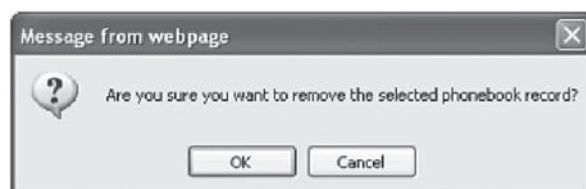

The screenshot shows a dialog box titled "Message from webpage" with a close button (X) in the top right corner. It contains a question mark icon and the text "Are you sure you want to remove the selected phonebook record?". Below the text, there are two buttons: "OK" and "Cancel".

Sending SMS from the Phonebook

Follow these steps to send SMS from the Phonebook:

1. Select the entry from the Phonebook list.
2. Click **Send SMS**.
The Phonebook console switches over to the Compose SMS console.

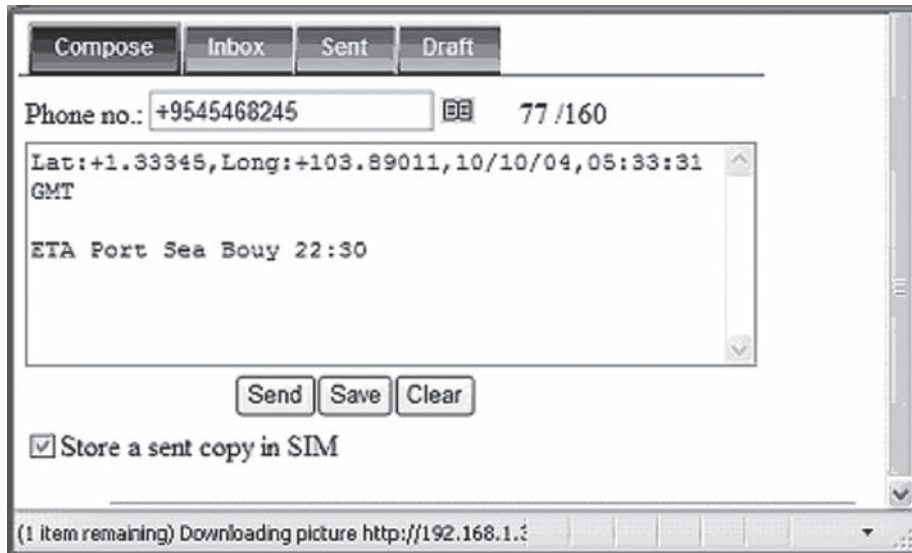

3. Type in the text message and click Send.
 - Click Refresh to refresh the Phonebook list.

Call History

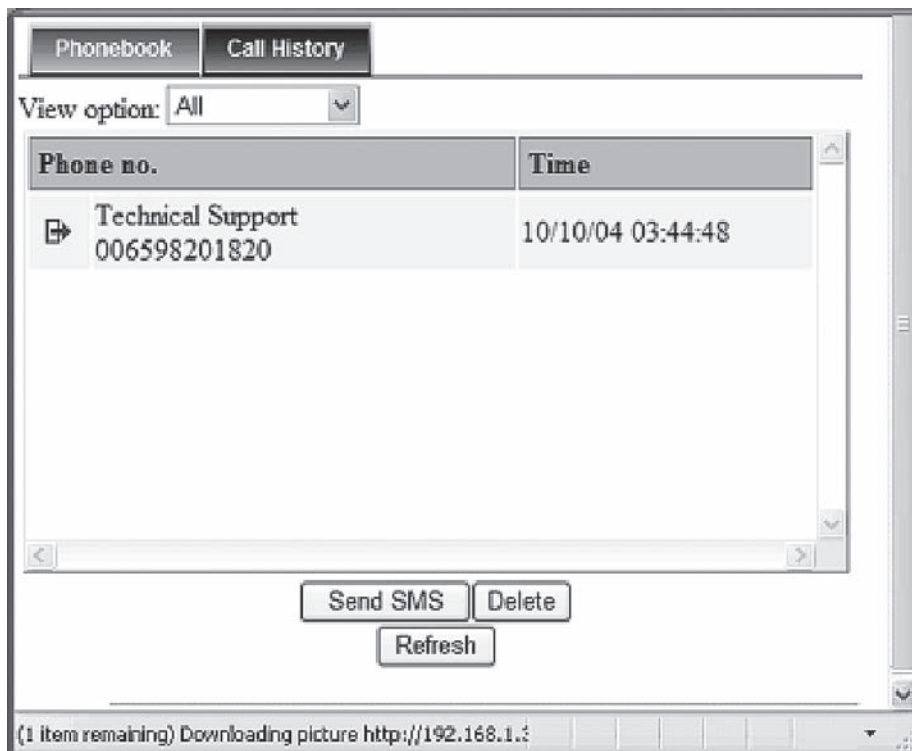

- **View option**

The View option allows you to view the Call History entries.

From the drop-down menu, select:

All	To view the list of the dialed, received and missed calls.
Dialed Call	To view the list of dialed calls only.
Received Call	To view the list of received calls only.
Missed Call	To view the list of missed calls only.

Sending SMS from the Call History list

Follow these steps to send SMS from the Call History list:

1. Select the entry from the list.
2. Click **Send SMS**.

The Call History console switches over to the Compose SMS console.

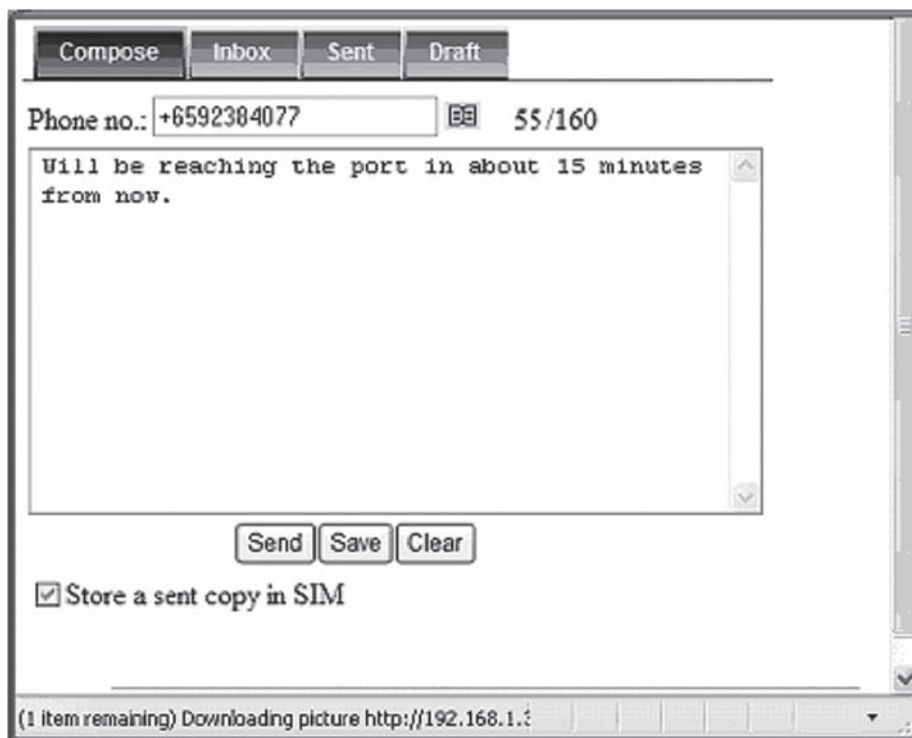

3. Type in the text message and click **Send**.

Deleting a Call History entry

Follow these steps to delete a Call History entry:

1. Select the entry from the Call History list.
2. Click **Delete**.
3. Click **Ok** to confirm or click **Cancel** to abort deleting the entry.
 - Click **Refresh** to refresh the Call History list.



SMS Menu

SMS menu provide the following options:

- **Compose**
To compose and send text messages. Simply enter a mobile number, type your message and click **Send**.
- **Inbox**
Shows the details (Sender information, Message, Date and Time stamp) of all SMS received.
- **Sent**
Shows the details (Receiver information, Message, Date and Time stamp) of all SMS sent.
- **Draft**
Stores unsent messages for retrieval later.

SAFARI™ WEB CONSOLE

inmarsat

wideye™ liberating communications

Setup Phone SMS Data Settings

Compose Inbox Sent Draft

Phone no.: 0 / 160

Send Save Clear Append GPS

Store a sent copy in SIM



Composing a New Message

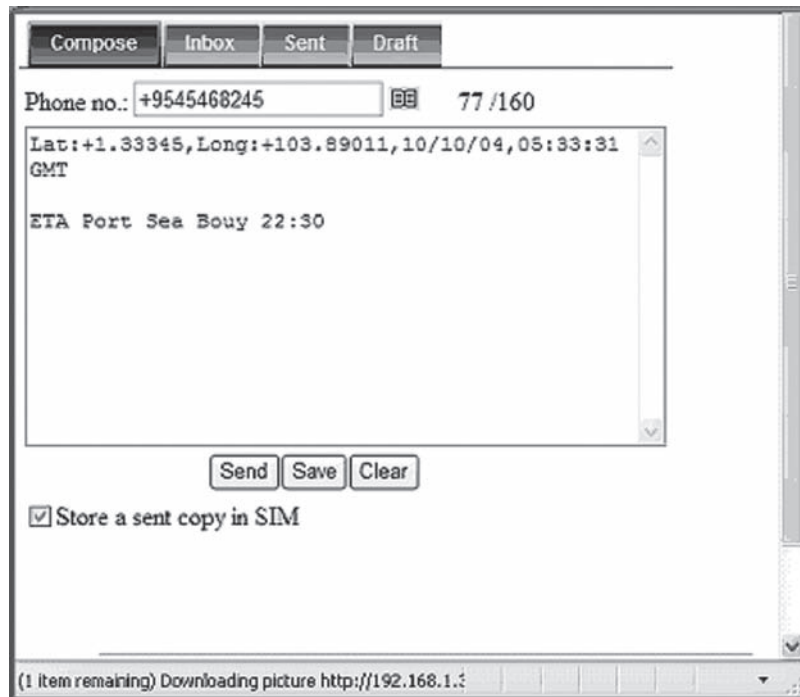

Follow these steps to compose a new SMS:

1. Enter the receiver's phone number in the **Phone no.** field or click the Phonebook icon  if the receiver's number is listed in the Phonebook
2. Type the message in the text editor box.

Note:

Message is limited to 160 characters (using 7 bit encoded default alphabets) including spaces between words. But it is limited to 70 characters per message using Unicode (UCS2) text message (such as message typed in Chinese, Japanese, etc). For sending a long SMS to another BGAN transceiver, the message is limited to 608 characters (using 7 bit encoded default alphabet) or 266 characters using Unicode (UCS2) text messages including spaces between words.

3. Uncheck **Store a copy in SIM** checkbox if you do not wish to store a copy of the sent SMS into SIM card.
4. Click **Send** to send the SMS.
 - To save an unsent SMS, click **Save** and the unsent SMS will be saved in **Draft**.
 - To clear the typed message on the text editor, click **Clear**.

Inbox

Shows the details (Sender information, Message, Date and Time stamp) of all SMS received.

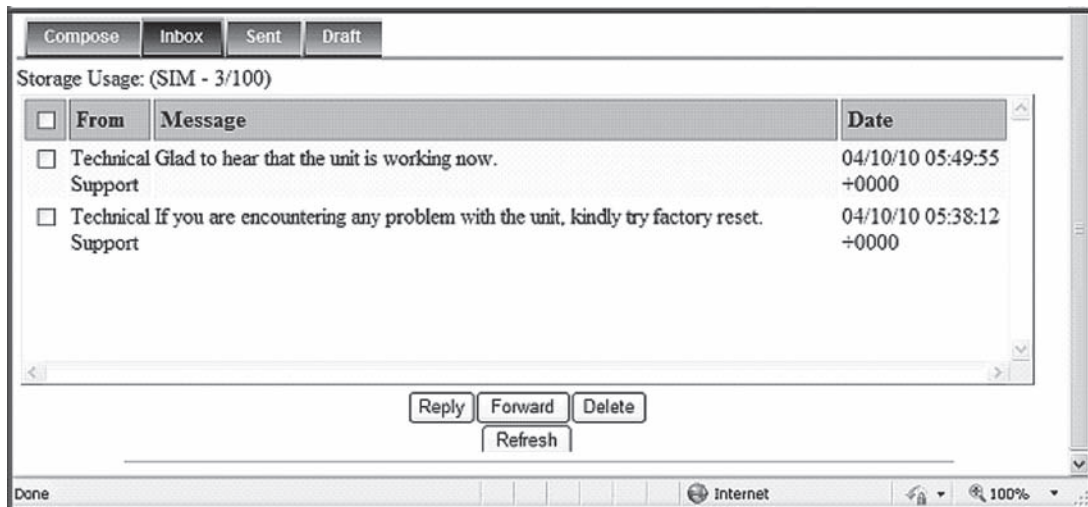

Replying to a SMS

Follow these steps to reply a SMS:

1. Click on a SMS to select it.
The selected SMS will be highlighted in light blue.
2. Click **Reply**.
3. Click **OK** to reply with the original contents or **Cancel** to reply without the original content.

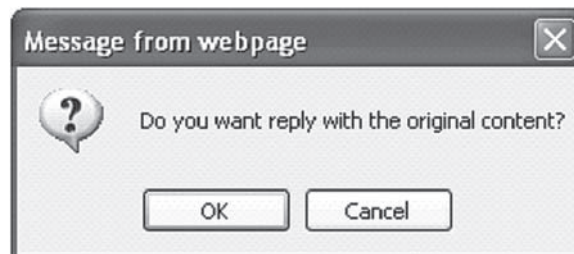

The Inbox console switches over to the Compose console.

4. Enter your reply in the text editor.
5. Click **Send** to send your reply SMS.
The reply SMS will be sent to the recipient.

Forwarding an SMS

Follow these steps to forward an SMS:

1. Click on a SMS to select it.
The selected SMS will be highlighted in light blue.
2. Click **Forward**.
The Inbox console switches over to the Compose console.
3. Enter the receiver's number in the **Phone No.** field.
4. Click **Send** to forward the SMS. The SMS will be sent to the recipient.

Deleting a single SMS from the Inbox list

Follow these steps to delete a single SMS from the Inbox list:

1. Click on a SMS to select it.
2. Click **Delete**.
3. Click **OK** to confirm or click **Cancel** to abort deleting the SMS.

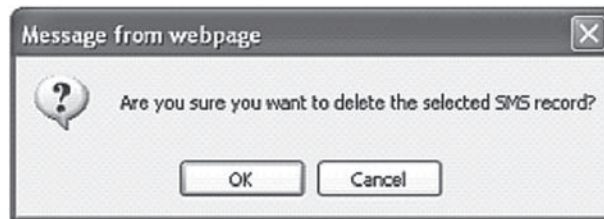

Deleting multiple SMS from the Inbox list

Follow these steps to delete multiple SMS from the Inbox list:

1. Select the message by checking the checkboxes beside each SMS.
2. Click **Delete**.
3. Click **OK** to confirm the delete, or **Cancel** to abort the delete.
 - Click **Refresh** to refresh the Inbox list.

Sent

Shows the details (Receiver information, Message, Date and Time stamp) of all SMS sent.

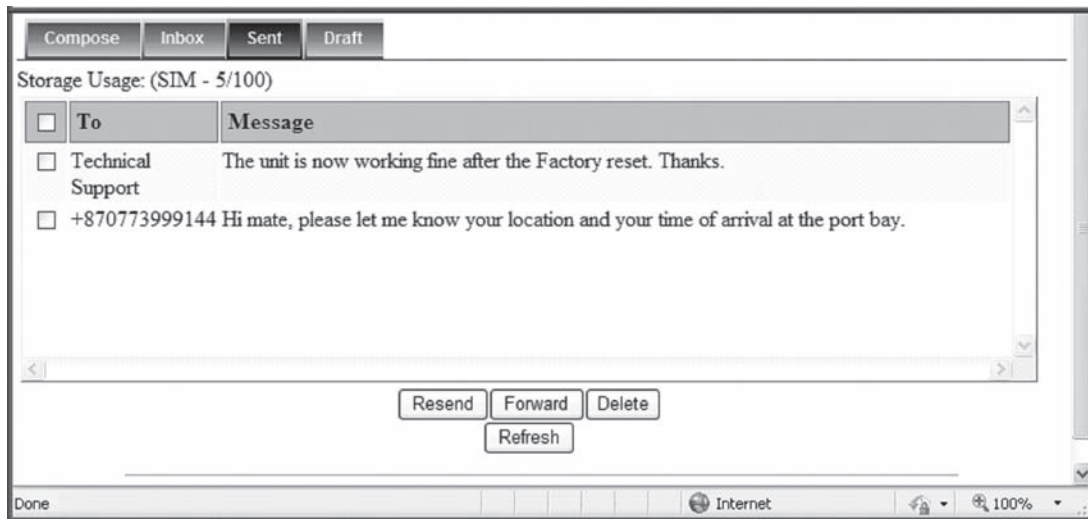

Resending a sent SMS

Follow these steps to resend a sent SMS (sending the same SMS to the same receiver):

1. Click on a SMS to select it.
2. Click **Resend**.
The SMS will be sent to the recipient.

Forwarding a sent SMS

Follow these steps to forward a sent SMS to another recipient:

1. Click on a SMS to select it.
2. Click **Forward**.
The Sent console switches over to the Compose console.

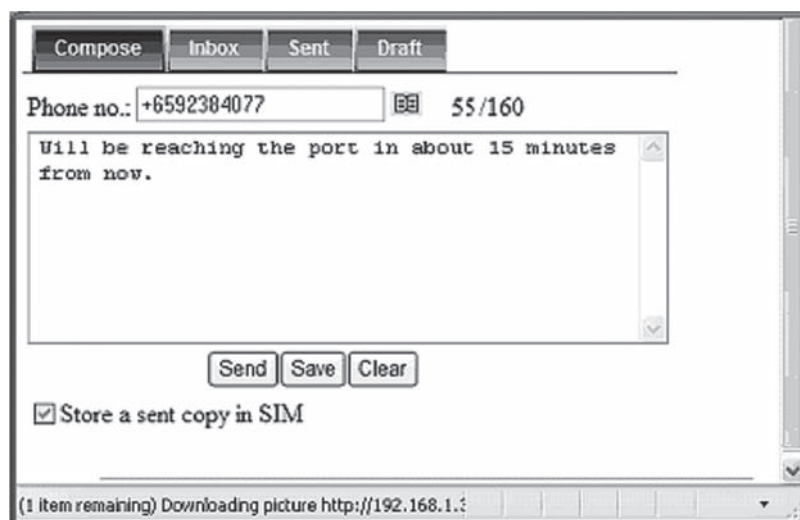

3. Enter the receiver's number in the **Phone No.** field.
4. Click **Send**.
The SMS will be sent to the recipient.

Deleting a SMS from the Sent list

Follow these steps to delete a single SMS from the Sent list:

1. Click on a SMS to select it.
2. Click **Delete**.
3. Click **OK** to confirm or click **Cancel** to abort deleting the SMS.

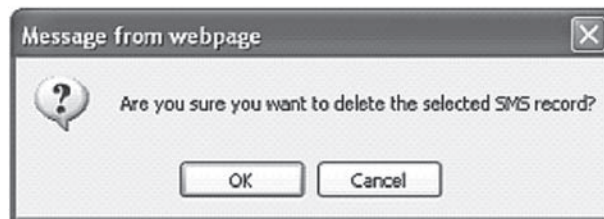

Deleting multiple SMS from the Sent list

Follow these steps to delete multiple SMS from the from the Sent list:

1. Select the message by checking the checkboxes beside each SMS.
 2. Click **Delete**.
 3. Click **OK** to confirm the delete, or **Cancel** to abort the delete.
- Click **Refresh** to refresh the Sent list.

Draft

Stores SMS saved from the Compose console.

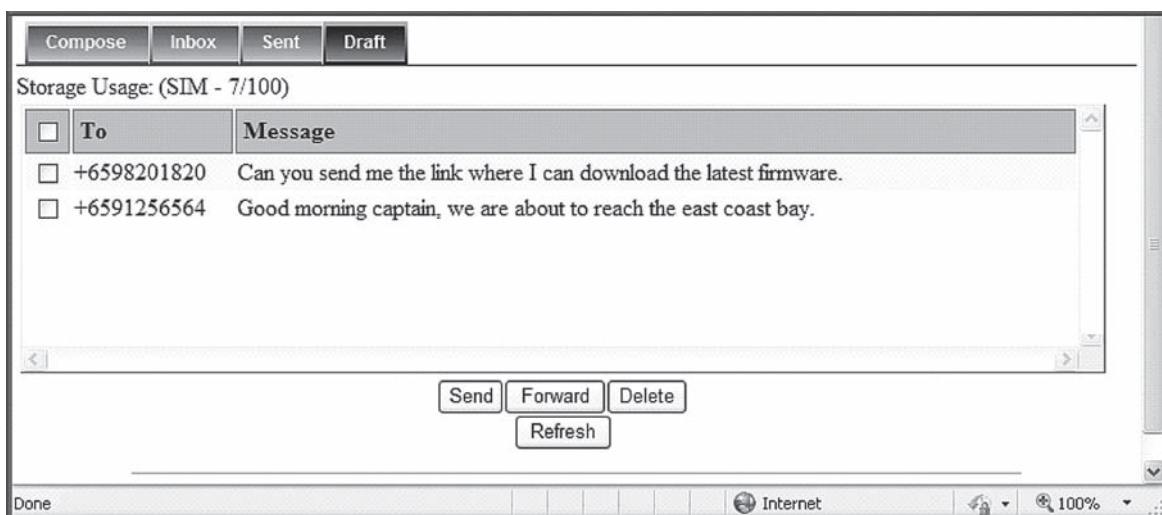

Follow these steps to send a draft SMS:

1. Click on a SMS to select it.
2. Click **Send**.
The SMS will be sent to the recipient.

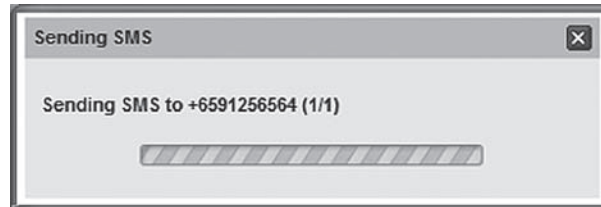

Forwarding a draft SMS to another recipient

Follow these steps to forward a draft SMS to another recipient:

1. Click on a SMS to select it.
2. Click **Forward**.
The Draft console switches over to the Compose console.

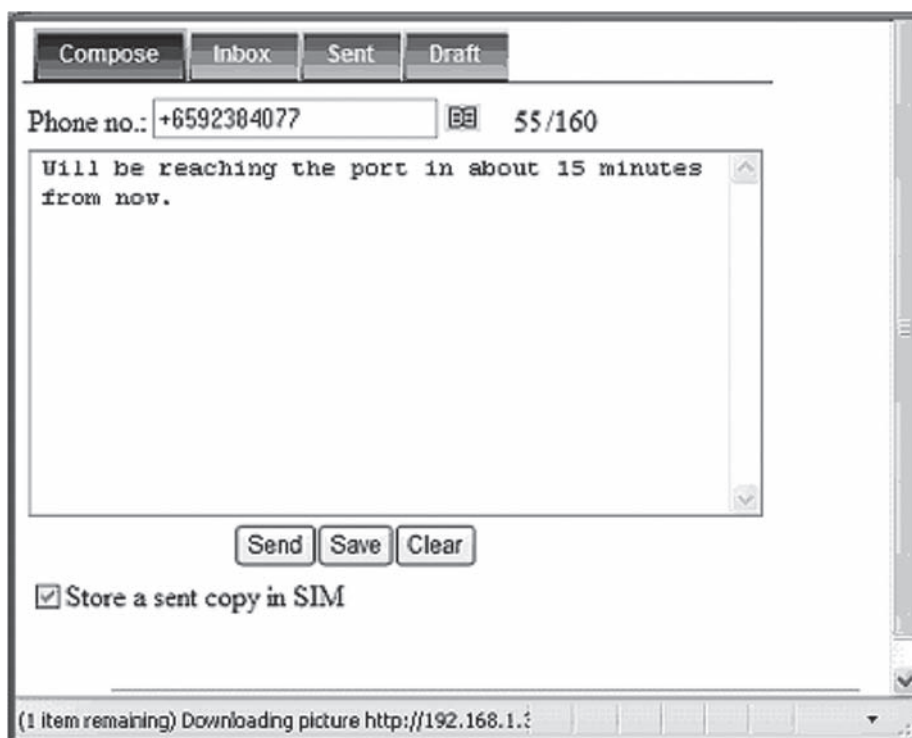

3. Enter the receiver's number in the **Phone No.** Field.
4. Click **Send** to forward the SMS.
The SMS will be forwarded to the recipient.

Deleting a SMS from the Draft list

Follow these steps to delete a SMS from the Draft list:

1. Click on a SMS to select it.
2. Click **Delete**.
3. Click **OK** to confirm or click **Cancel** to abort deleting the SMS.

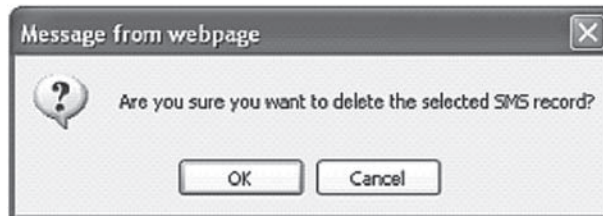

Deleting multiple SMS from the Draft list

Follow these steps to delete multiple SMS from the Draft list:

1. Select the message by checking the checkboxes beside each SMS.
2. Click **Delete**.
3. Click **OK** to confirm the delete, or **Cancel** to abort the delete.
 - Click **Refresh** to refresh the Draft list.



Data Menu

Data menu provides the following options:

- **Connection**
- **Primary Profiles**
- **Secondary Profiles**
- **Port Forwarding**
- **Settings**

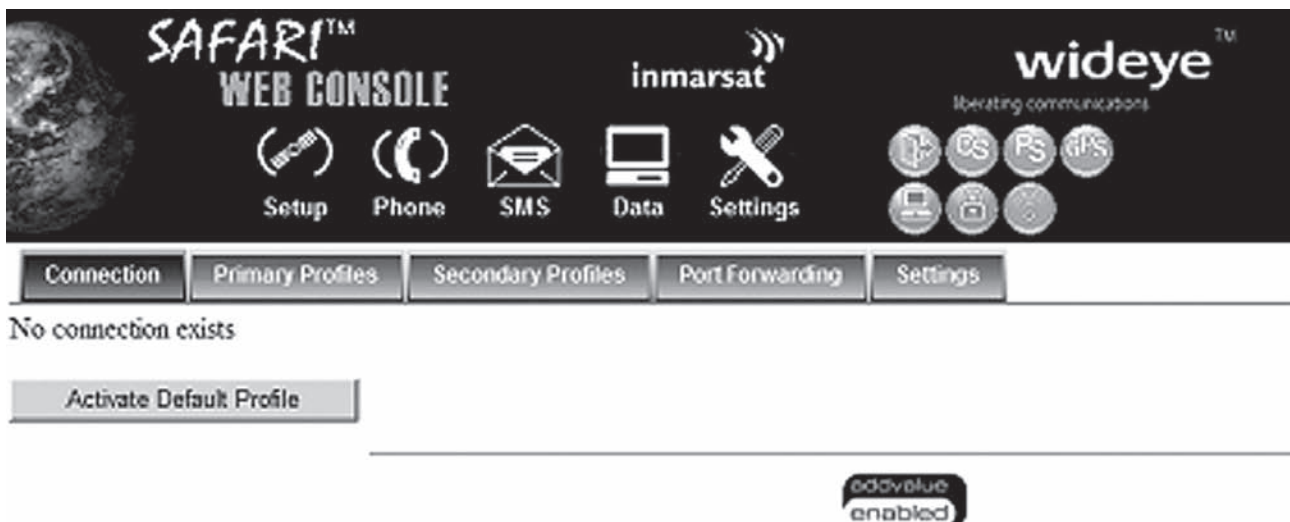

Connection

To activate the default profile, click **Activate Default Profile**. The PDP context will be activated.

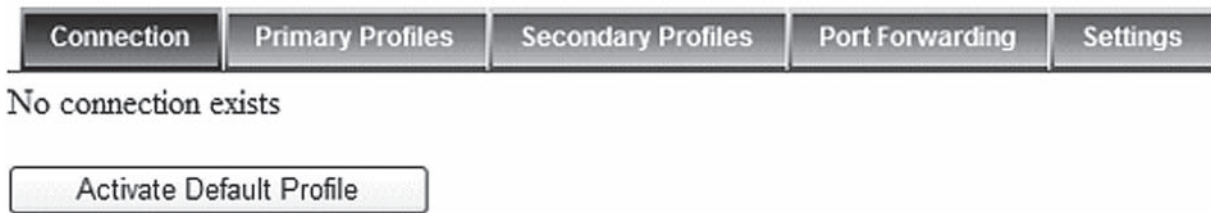

When connected, APN and the assigned public IP Address details will be displayed. You can proceed to access the Internet and use the related features.

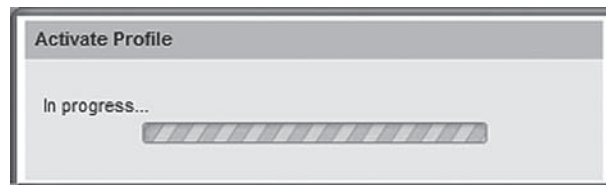

To disconnect the data connection, click **Disconnect**. The PDP context will be deactivated.

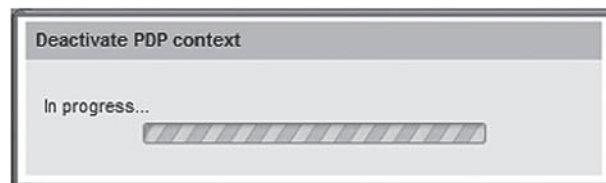

Primary Profiles

Primary profiles define the connection type. You can select from a list of profiles to be the default primary profile and connection type. From Profile 7 to Profile 10, you can create your own customized primary profile.

Connection	Primary Profiles	Secondary Profiles	Port Forwarding	Settings
------------	------------------	--------------------	-----------------	----------

- *Standard
- Streaming32k
- Streaming64k
- Streaming128k
- Profile 5
- Profile 6
- Profile 7
- Profile 8
- Profile 9
- Profile 10

Refresh

Set as default

Profile Name:

Connection Type:

Standard

Streaming

Access Point Name (APN):

SIM

User Defined

Username:

Password:

IP Configuration:

Dynamic IP Address

Static IP Address ...

Use Header Compression

Limited Connection:

Time

Duration: minutes

Notification Before Expired: minutes

Volume

Traffic Volume: MB

Standard

Using this connection type you will be charged for the **VOLUME** (kilobytes) of data used. Use this connection type for TCP/IP applications, data exchange and transfer such as Email, Internet Browsing, FTP, etc.

Note:

The Standard profile is set as the default primary profile and the default connection type is standard (this is charged by the volume [in kilobytes] of data used).

- **Profile Name**
Change the profile name as desired.
- **Connection Type**
Change the type of connection. By default the connection type will be standard.
- **Access Point Name (APN)**
By default, the APN from the SIM will be selected.

Follow these steps to change the **Access Point Name (APN)**:

1. Select **User Defined**.
2. Enter the new APN in the field space provided (e.g. BGAN inmarsat.com).
3. Enter the username and password if required.

- **IP Configuration**

By default, the **Dynamic IP Address** is selected.

Follow these steps to use **Static IP Address**:

1. Select **Static IP Address** and enter the IP Address in the space provided.
2. Check the **Header Compression** checkbox if it is required to use Header Compression.

- **Limited Connection**

To manage the usage of data by setting a limit to the duration used in minutes or volume in MB. This is especially useful when user tends to leave the terminal unattended, with data connection active and resulting unexpected data usage by applications running on PC such as Windows updates and etc.

1. Check on the options (either Time, Volume or both)
2. Enter the desired duration or volume

Secondary Profiles

Connection Primary Profiles **Secondary Profiles** Port Forwarding Settings

FTP
Quick Link
Quick Time Mec
Real Media
Streambox
Win Media
Profile 7
Profile 8
Profile 9
Profile 10

Refresh

Profile Name:

Streaming Parameters:
Desired Rate:
Minimum Rate:
 Use error correction

Destination Port Ranges:

From	To	Protocol	
20	21	TCP	Delete

[Add from Templates](#)

Limited Connection:
 Time
Duration: minutes
Notification Before Expired: minutes
 Volume
Traffic Volume: MB

addvalue enabled

Secondary profiles setting are used mainly for streaming connection. You may select one of the secondary profiles to be used during streaming connection. You may also create a customized secondary profile; choose from profile 7 to 10.

It also has the same time/volume limited data connection feature as the Primary Profiles.

Port Forwarding

Port Forwarding is a feature for Router (multiple-user) mode. This feature sets the SAFARI™ TU to direct incoming traffic on certain TCP/UDP port to a specific port on a local PC (IP Address).

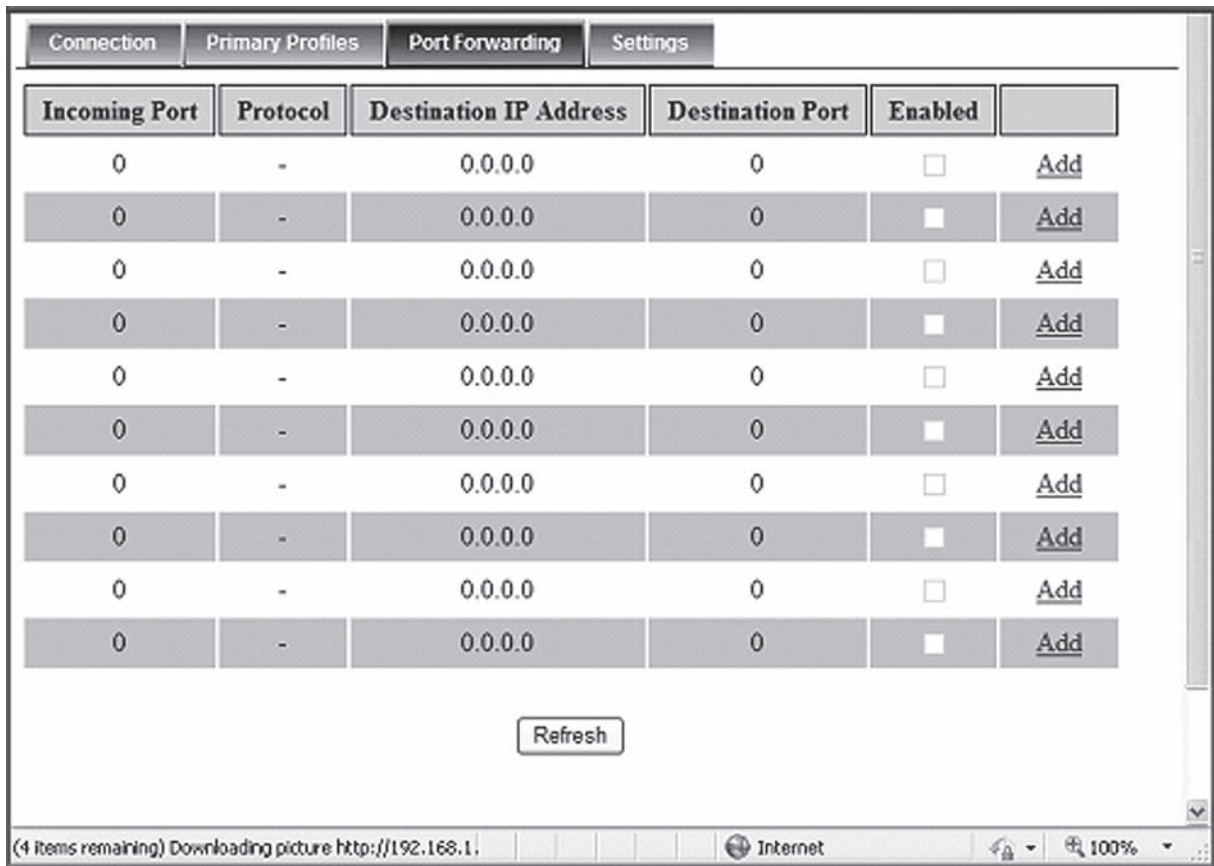

Follow these steps to add a new forwarding rule:

1. Click **Add**.

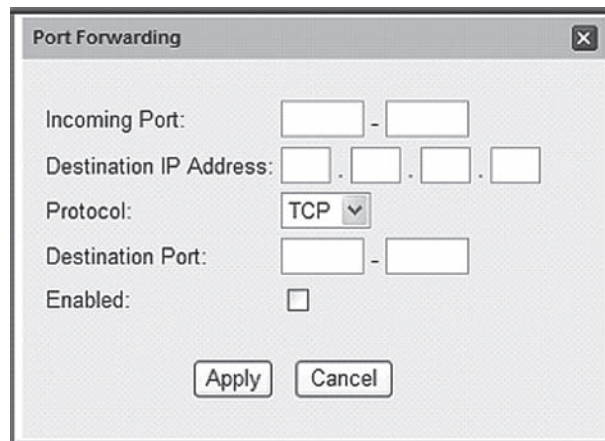

2. Enter the **Incoming Port** number in the space provided.
(For example, the user expecting HTTP traffic, the port is 80).
3. Enter the **Destination IP Address**.
(For example, the IP Address of the PC that is connected to the SAFARI™ TU).
4. Select the **Protocol** type:
 - TCP (e.g. for HTTP, it will be TCP)
 - UDP

5. Enter the **Destination Port** number in the space provided (For example: listening port of the particular service (for example TCP port 80 for web server) on the PC that is connected to the SAFARI™ TU).
6. Click **Apply** to allow the settings to take effect.

Settings

You can select the Ethernet mode to be used for data connection.

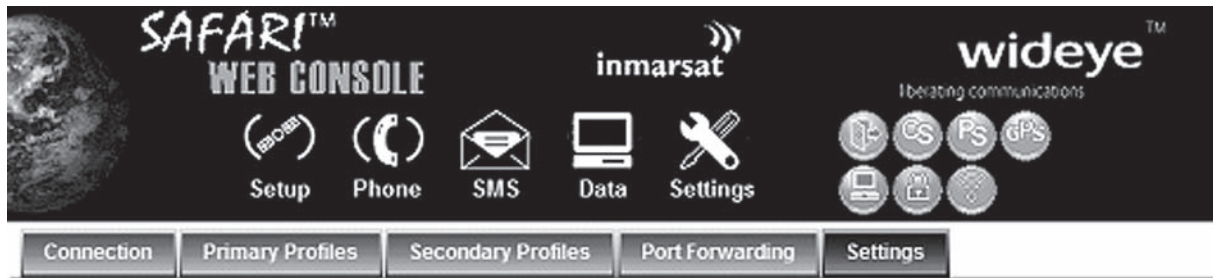

Ethernet mode:

- Router Mode (Single User)
 - Router Mode (Multi-User)
 - Always On (Auto PDP Context Activation)
- Default Primary Profile: Standard

Update

Refresh



Follow these steps to select the Ethernet mode:

1. Select the desired mode to be used during the data connection:
 - Router (Single User) is with NAT/PAT disabled
 - Router (Multi-User) is with NAT/PAT enabled for multi-user.

Note:

You cannot change the Router settings while a Data connection is active, you must first disconnect you Data session.

2. Check “Always On (Auto PDP Context Activation)” if required.
3. Click **Update** to allow the selection to take effect.
 - Click **Refresh** to query the current mode.



Settings Menu

Click the following tabs to view and edit the configuration settings for the SAFARI™ TU:

- Language
- Transceiver Info
- Ethernet
- Telephony
- PIN
- SMS
- Wi-Fi
- Admin
- Support
- Accounts
- About

Language

Select the desired language (Chinese-Simplified and Chinese-Traditional, Spanish or Nederland) for the Web Console to be displayed.

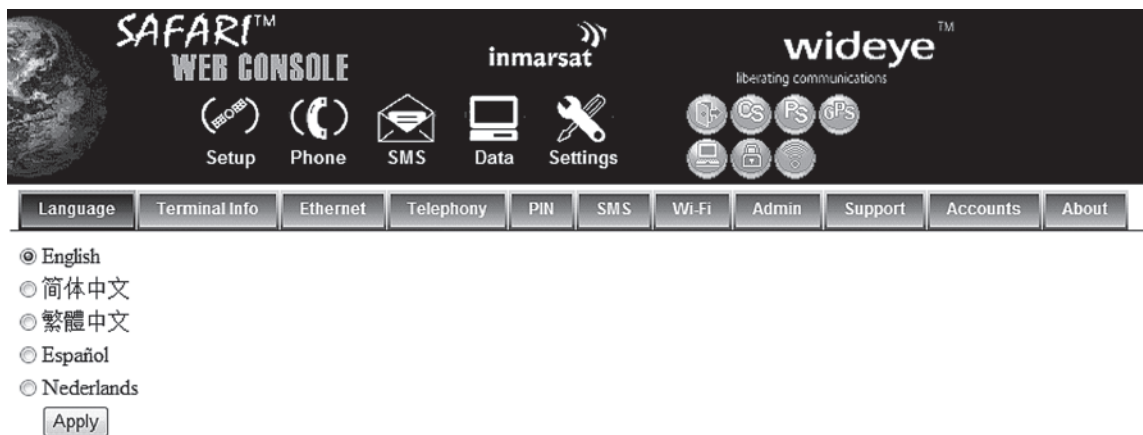

Transceiver Info

This tab shows general information about the TU, Error/Event Logs and Call Logs.

- **Information**

Displays information about the Manufacture ID, Software version, Model ID, IMEI number, IMSI number (only when a SIM card is inserted), Subscriber number and Antenna Unit's serial Number.

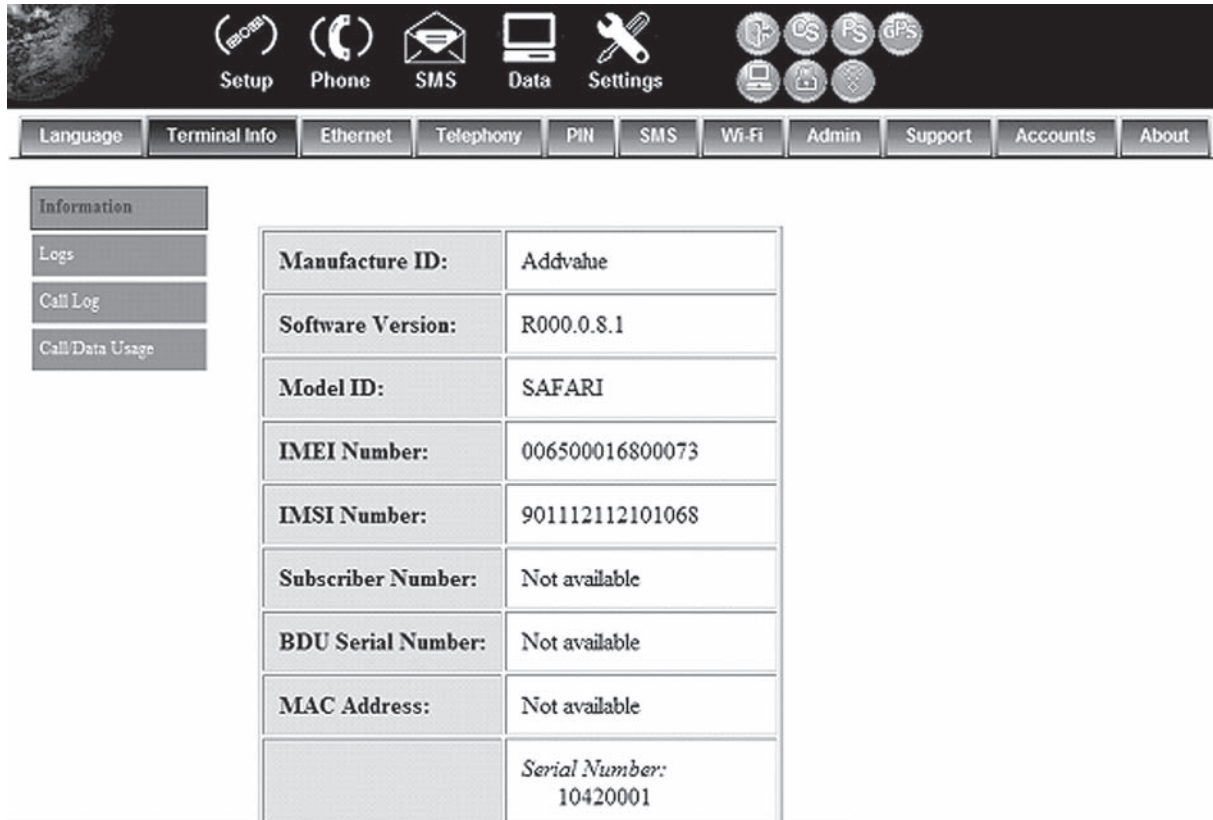

The screenshot shows a user interface for a transceiver. At the top, there is a dark navigation bar with icons for Setup, Phone, SMS, Data, Settings, and various network services (CS, PS, GPS, Wi-Fi, etc.). Below this is a horizontal menu with buttons for Language, Terminal Info, Ethernet, Telephony, PIN, SMS, Wi-Fi, Admin, Support, Accounts, and About. The 'Information' tab is selected, and a sidebar on the left contains buttons for Information, Logs, Call Log, and Call Data Usage. The main content area displays a table with the following information:

Manufacture ID:	Advvalue
Software Version:	R000.0.8.1
Model ID:	SAFARI
IMEI Number:	006500016800073
IMSI Number:	901112112101068
Subscriber Number:	Not available
BDU Serial Number:	Not available
MAC Address:	Not available
	<i>Serial Number:</i> 10420001

- **Logs**
Displays event and error logs of the TU.

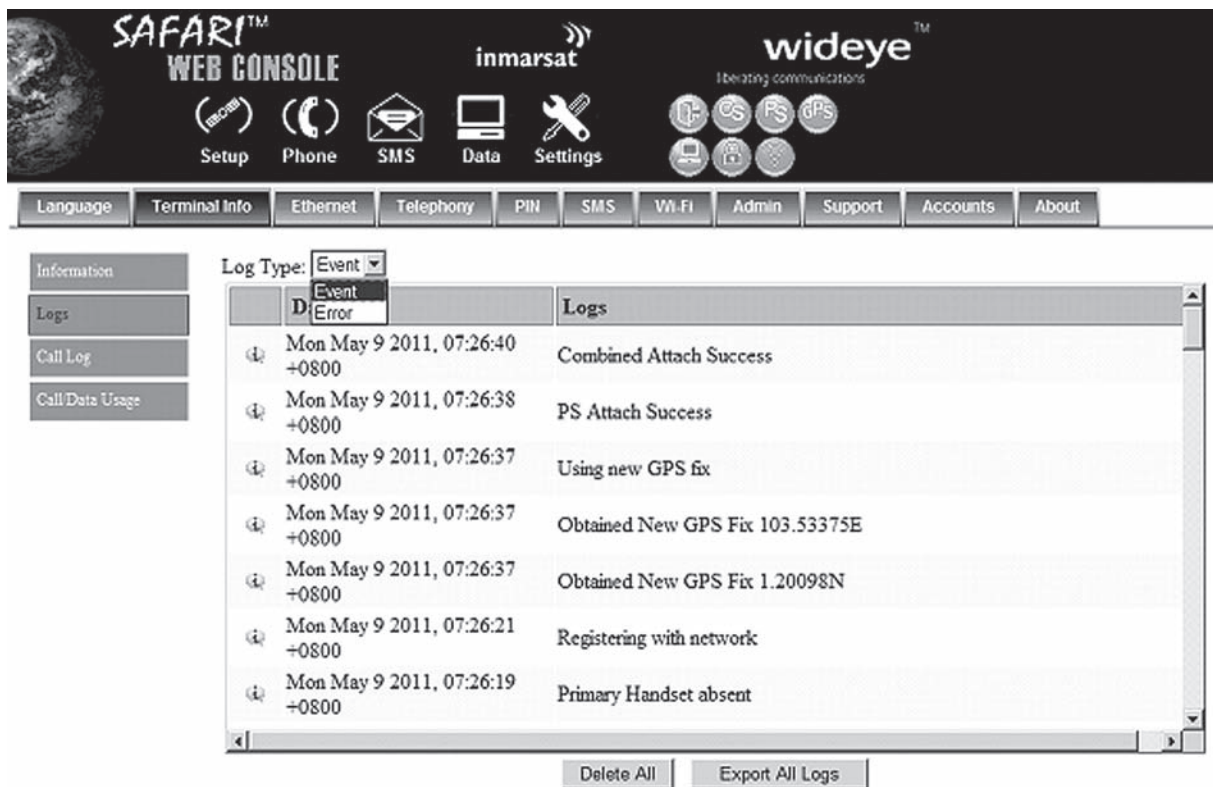

- **Call Log**
Displays the call history including standard voice calls, high-quality/fax calls, standard data sessions and streaming data sessions.

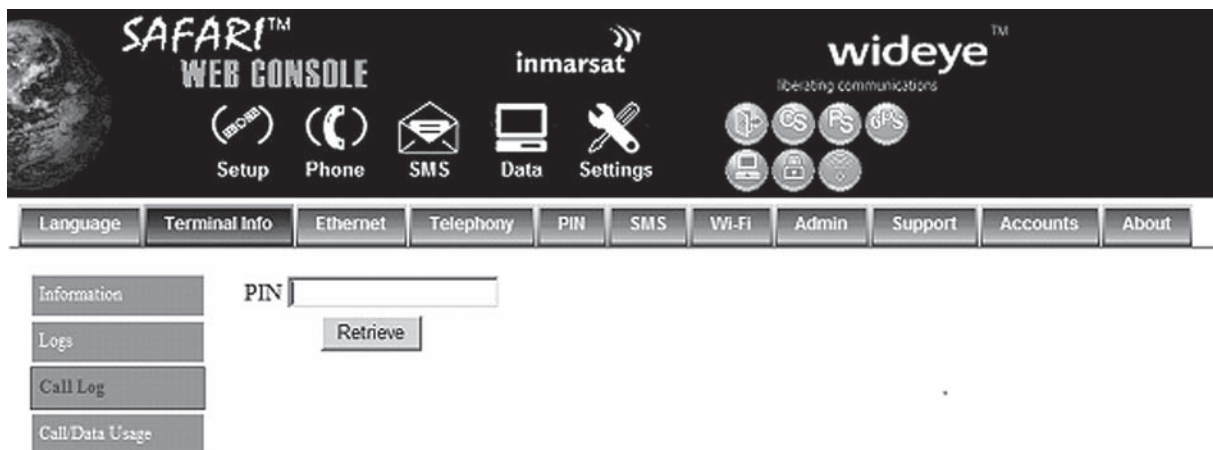

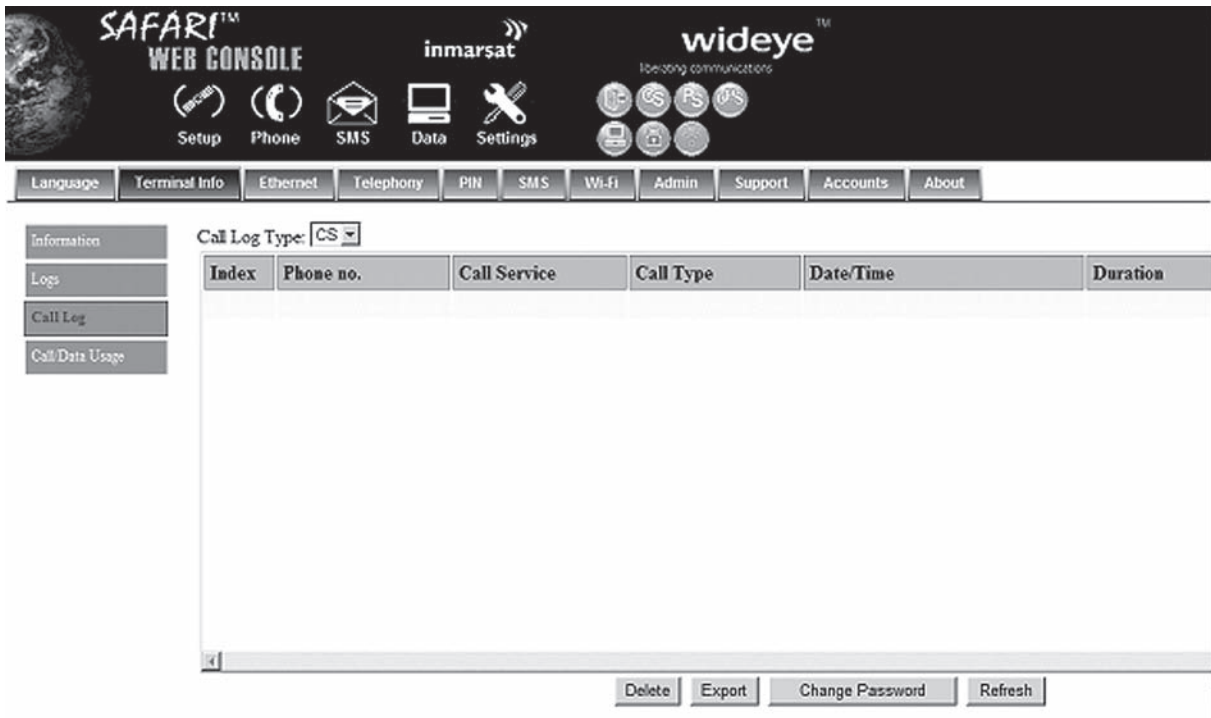

Ethernet

- **Ethernet**
 1. Click **Ethernet** to view and edit the Ethernet settings.
 2. Click **Update** to allow the settings to take effect.

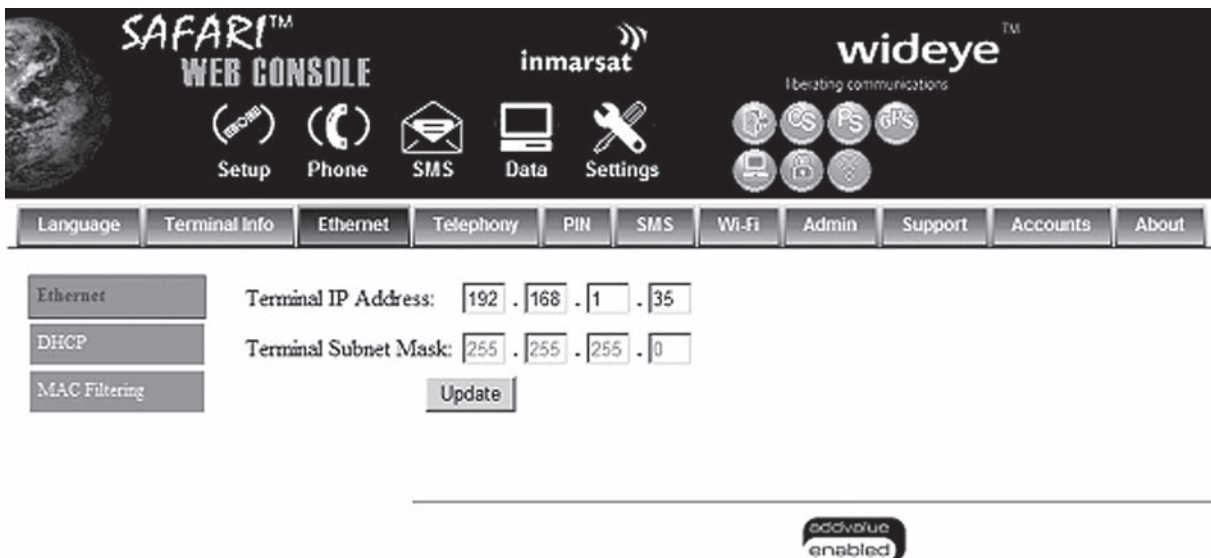

- **DHCP**

1. Click **DHCP** to view and edit the DHCP settings.
2. Click **Update** to allow the settings to take effect.



- **Mac Address Filtering**

1. Click **Mac Filtering** to view and edit the Mac Filtering settings.
2. Click **Update** to allow the settings to take effect.

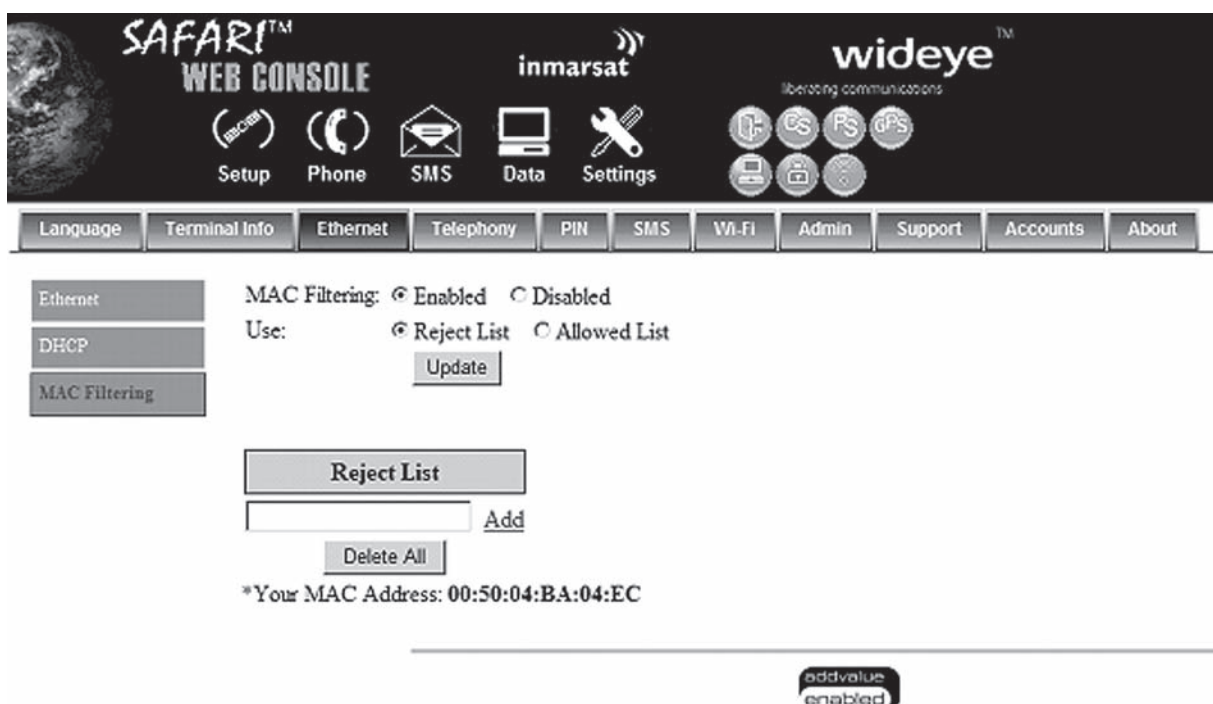

- Reject List
All PCs/Laptops will be allowed to access the TU except for those (MAC addresses) listed in the Reject List.
- Allow List
All PCs/Laptops will be denied access to the TU except for those (MAC addresses) listed in the Allow List. When selecting this list, at least one entry should be there to access the TU.

Telephony

- Interface
 1. Select European Caller Line ID Phone connected or US Caller Line ID Phone connected from the Telephone Interface Configuration drop-down menu.
 2. Click Update to allow the setting to take effect.

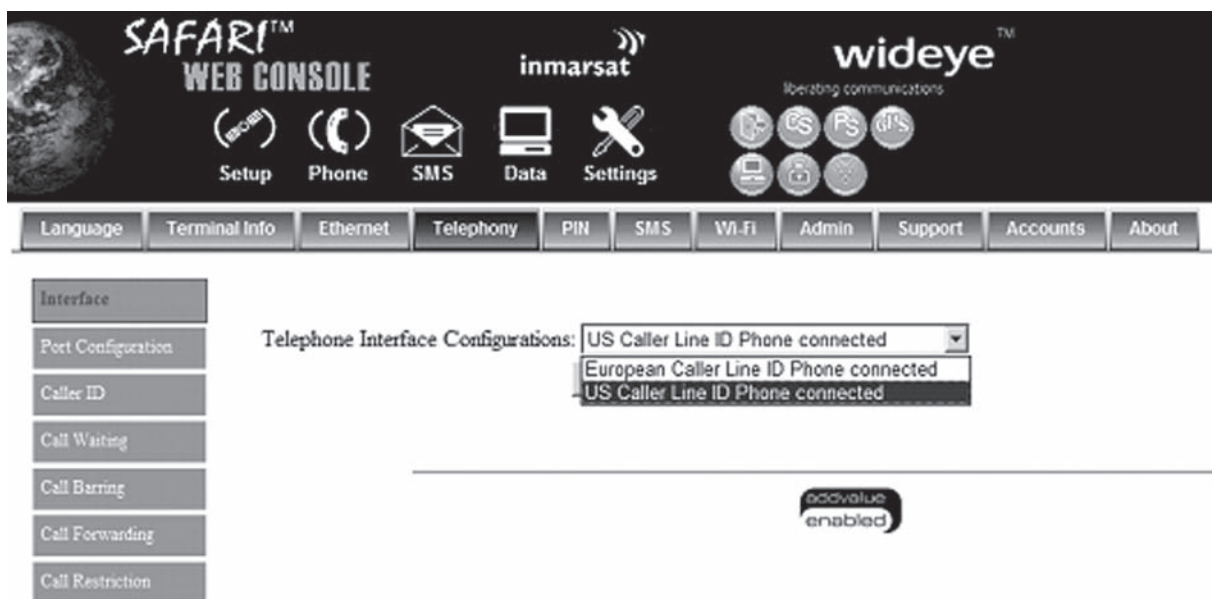

Port Configuration

For each of the 3 ports, a choice of the quality calls can be selected. Select your ideal call quality and click **Update**.

Primary Handset

Port	Call Type	Service Type	
Primary Handset	Incoming Call	Standard voice call Standard voice call None	Update
	Outgoing Call	Standard voice call Standard voice call None	Update

Phone Port

PHONE Port	Incoming Call	Standard voice call Standard voice call None	Update
	Outgoing Call	Standard voice call Standard voice call None	Update

Fax Port

For the fax port, if no subscription is made, there will be no choices.

FAX* Port	Incoming Call	None None	Update
	Outgoing Call	None None	Update

If fax subscription is made, 3.1kHz high quality fax call will be available.

FAX Port	Incoming Call	3.1kHz high quality voice/fax call 3.1kHz high quality voice/fax call None	Update
	Outgoing Call	3.1kHz high quality voice/fax call 3.1kHz high quality voice/fax call None	Update

- **Caller ID**

1. Click **Retrieve** to get current setting of the **Allow called party to see your number** configuration.
2. To change the setting, select **Yes**, **No**, or **According to network subscription** for the Allow called party to see your number configuration.
3. Click **Apply** to allow the setting to take effect.

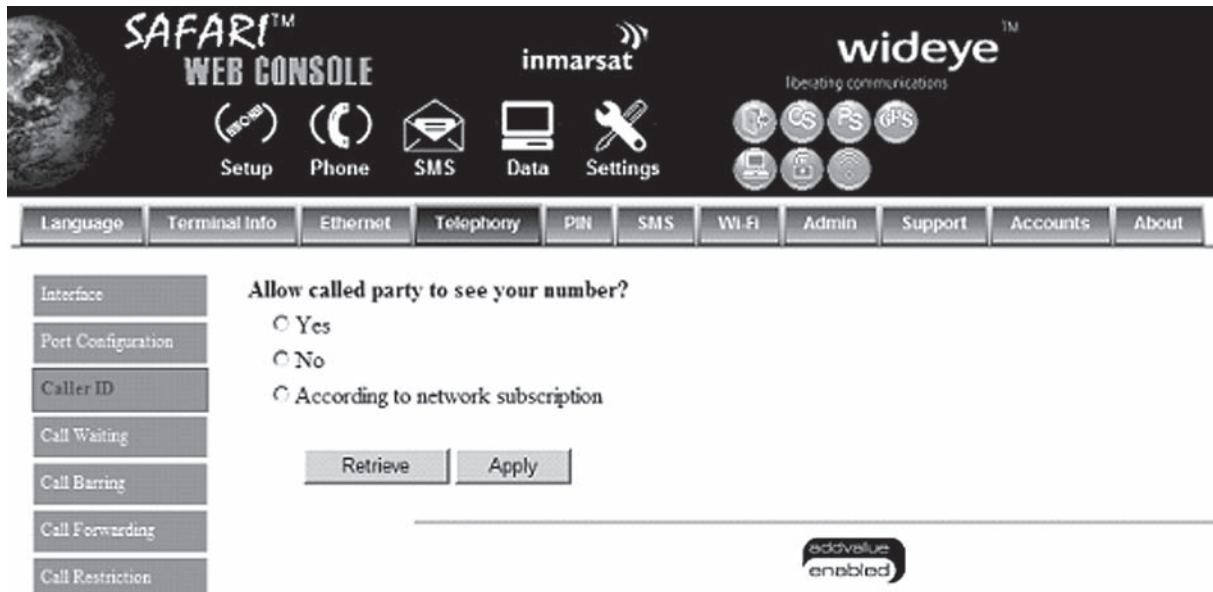

- **Call Waiting**

1. Click **Retrieve** to get current setting of the **Enable call-waiting** configuration.
2. To change the setting, select **Yes** or **No** for the **Enable call waiting** configuration.
3. Click **Apply** to allow the new setting to take effect.

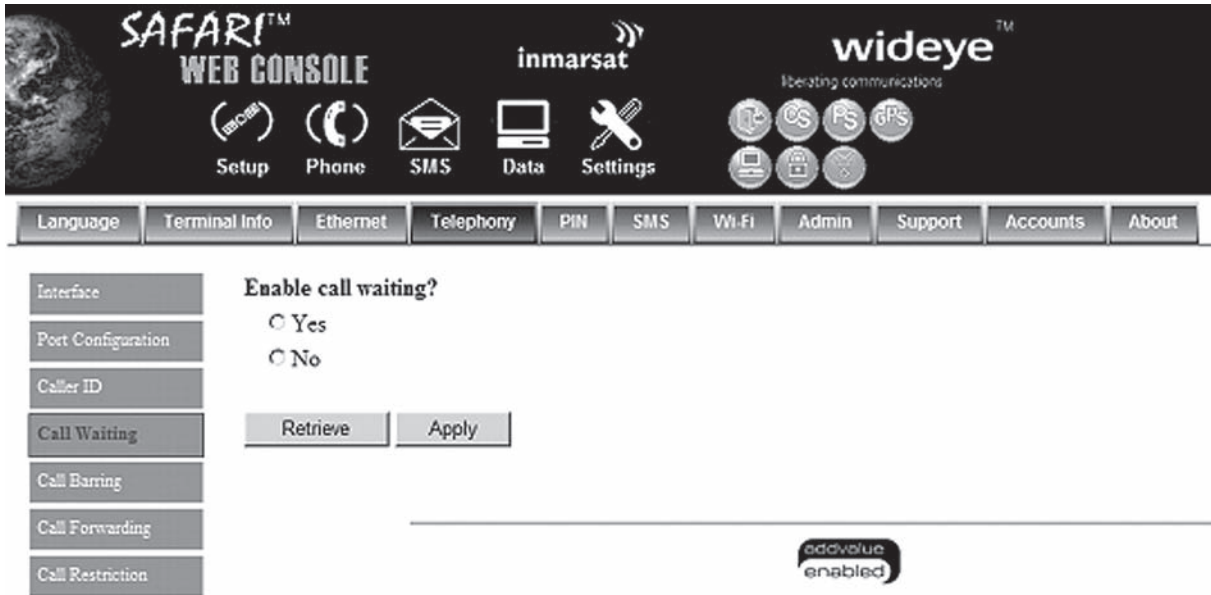

- **Call Barring**

1. Click any individual **Retrieve** option to get the current setting of the corresponding scenario in which the calls would be barred.
2. Select the scenario in which the calls would be barred, or deselect the scenario to disable the corresponding call barring.
3. In the **Barring PIN** field, input a PIN for call barring setup.
4. Click **Apply** to allow the corresponding setting to take effect.
5. Clicking **Retriever All** will retrieve the current settings of all four call barring scenarios at the same time.
6. Clicking **Apply All** will allow the settings of all four call barring scenarios to take effect at the same time.

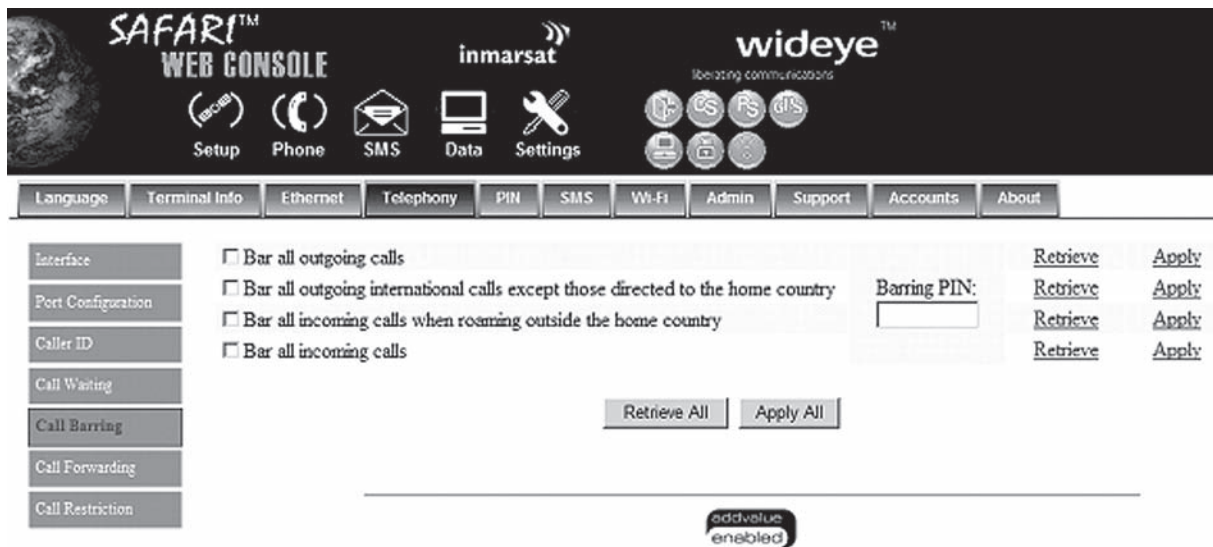

- **Call Forwarding**

1. Click any individual **Retrieve** option to get current setting of the corresponding scenario in which incoming calls would be forwarded.
2. Select the scenario in which the calls should be forwarded, or deselect the scenario to disable the corresponding call forwarding setting.
3. In the **Divert to Number** field, input the phone number where the incoming calls should be forwarded to (+<country code><telephone number>).
4. If the **Divert if not answered** option is selected, select from the **Divert After (seconds)** drop-down list, the period of time the network should wait before forwarding the calls.
5. Click **Apply** to allow the setting to take effect.
6. Clicking **Retrieve All** will retrieve the current settings of all four scenarios in which the calls would be forwarded, at the same time.
7. Clicking **Apply All** will allow the settings of all four scenarios to take effect at the same time.

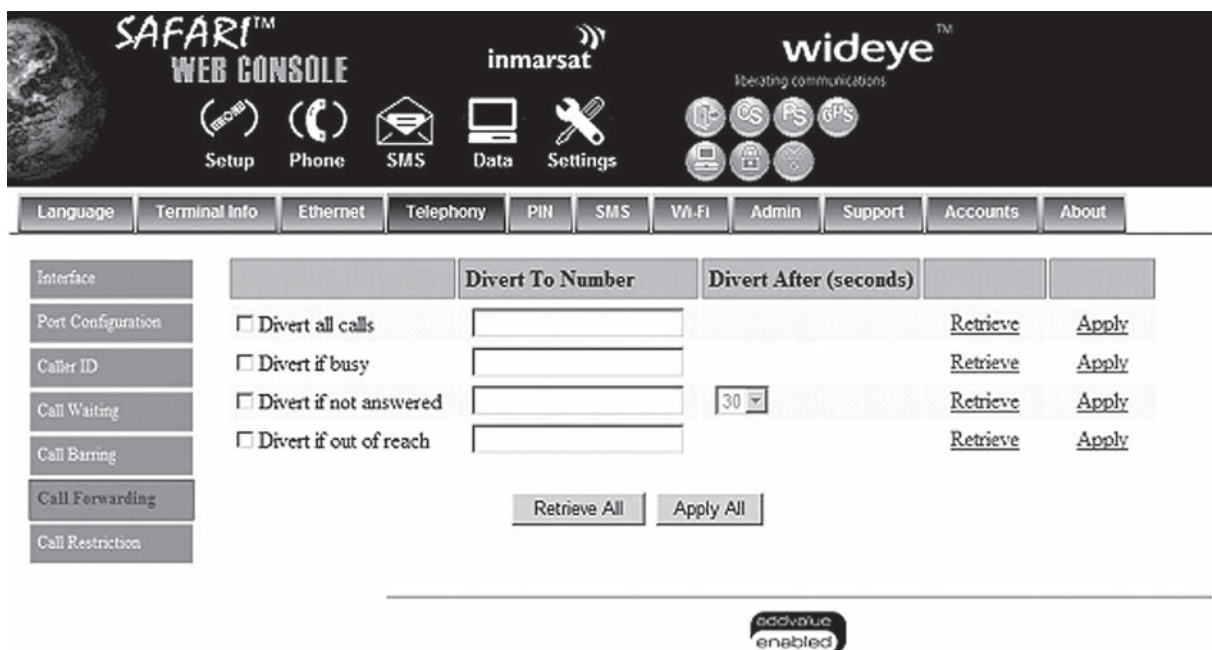

- **Call Restriction**

The Call Restriction is only enabled for outgoing call. There are 2 types of restriction:

1. Phonebook – The user is only able to make outgoing calls from the phonebook list.
2. Call List – In this segment, it further categorised into Allowed List and Blocked List for the 3 types of telephony functions.

- a. **Allowed List** – The administrator can either enter the telephone numbers or simply the country and/or area code to limit other users to make outgoing calls. If the administrator only enter one number or country code, users can only call this number or within the country.
 - b. **Blocked List** – Similar to the Allowed List, once the number or country and/or area code is entered, users are unable to make any outgoing calls through the number or within the country and/or area code specified in the list.
1. Select **Enabled** or **Disabled** to activate or deactivate call restriction respectively.
 2. Select **Call List** or **Phonebook** to choose which directory you want to be restricted by.
 3. Select **Allowed List** or **Block List** for each of the 3 ports to choose if that particular port numbers are the allowed or block list.

SAFARI™ WEB CONSOLE

inmarsat

wideye™ liberating communications

Setup Phone SMS Data Settings

Language Terminal Info Ethernet Telephony PIN SMS Wi-Fi Admin Support Accounts About

Interface

Port Configuration

Caller ID

Call Waiting

Call Barring

Call Forwarding

Call Restriction

Call Restriction: Enabled Disabled

Restrict By: Call List Phonebook

Primary Handset: Use as Allowed List Blocked List

006598712345

006512345678

PHONE Port: Use as Allowed List Blocked List

0065

001935

FAX Port: Use as Allowed List Blocked List

00852

Update

PIN

- **Transceiver PIN**

1. Click **Transceiver PIN** to configure the Transceiver PIN settings.
2. Select **Disabled** if you do not need to set the Transceiver PIN.
3. Select **Enabled** to set the Transceiver PIN.
4. Enter the PIN number in the Enter PIN field and click **Update PIN**.

Follow these steps to change the Transceiver **PIN**:

1. Enter the old PIN number in the **Enter Old PIN** field.
2. Enter the new PIN number in the **Enter New PIN** field.
3. Re-enter the new PIN number in the **Re-enter New PIN** field.
4. Click **Change PIN Password**.
The Transceiver PIN is now changed.

Note: The default Transceiver PIN is “0000”

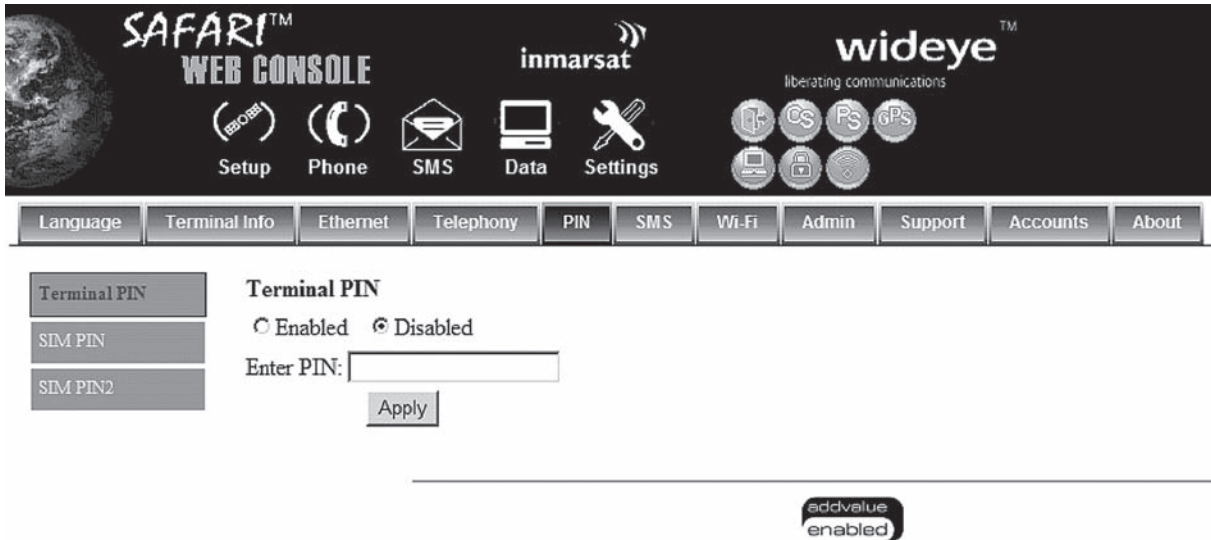

- **SIM PIN**

1. Click **SIM PIN** to configure the SIM PIN settings.
2. Select **Disabled** if you do not need to set the SIM PIN.
3. Select **Enabled** to set the SIM PIN.
4. Enter the PIN number in the space provided and click **Update PIN**.

Note: The SIM PIN depends on the SIM card. Consult your equipment distributor if necessary.

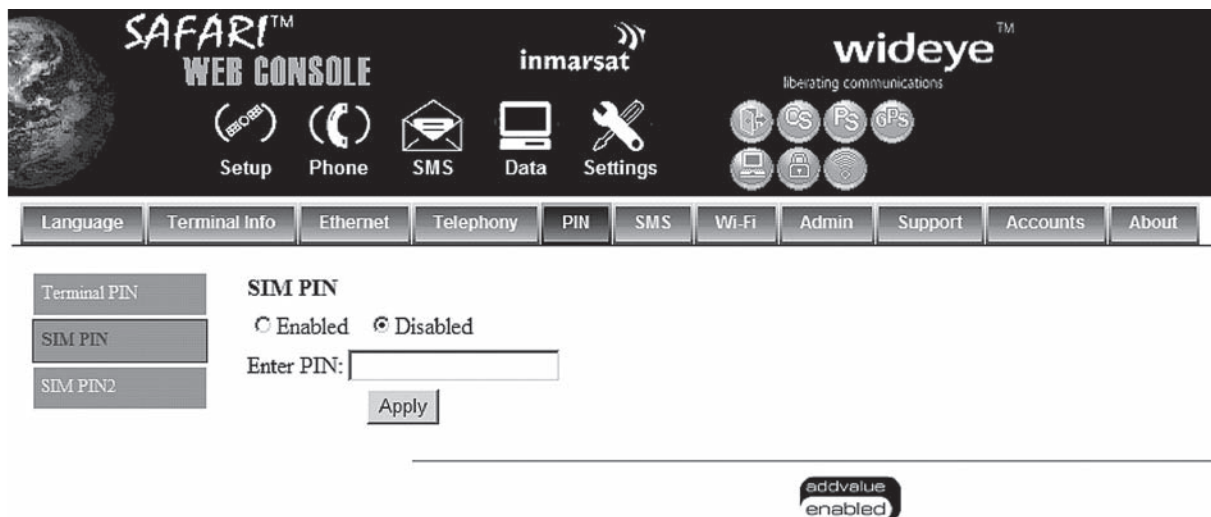

- **SIM PIN2**

1. Click **SIM PIN2** to configure the SIM PIN2 settings.
2. Select **Disabled** if you do not need to set the SIM PIN2.
3. Select **Enabled** to set the SIM PIN2.
4. Enter the PIN number in the space provided and click **Update PIN**.

Follow these steps to change the **PIN Password**:

5. Enter the old PIN number in the **Enter Old PIN** field.
6. Enter the new PIN number in the **Enter New PIN** field.
7. Re-enter the new PIN number in the **Re-enter New PIN** field.
8. Click **Change PIN Password**.
The Transceiver PIN is now changed.

Note: The SIM PIN2 depends on the SIM card. Consult your equipment distributor if necessary.

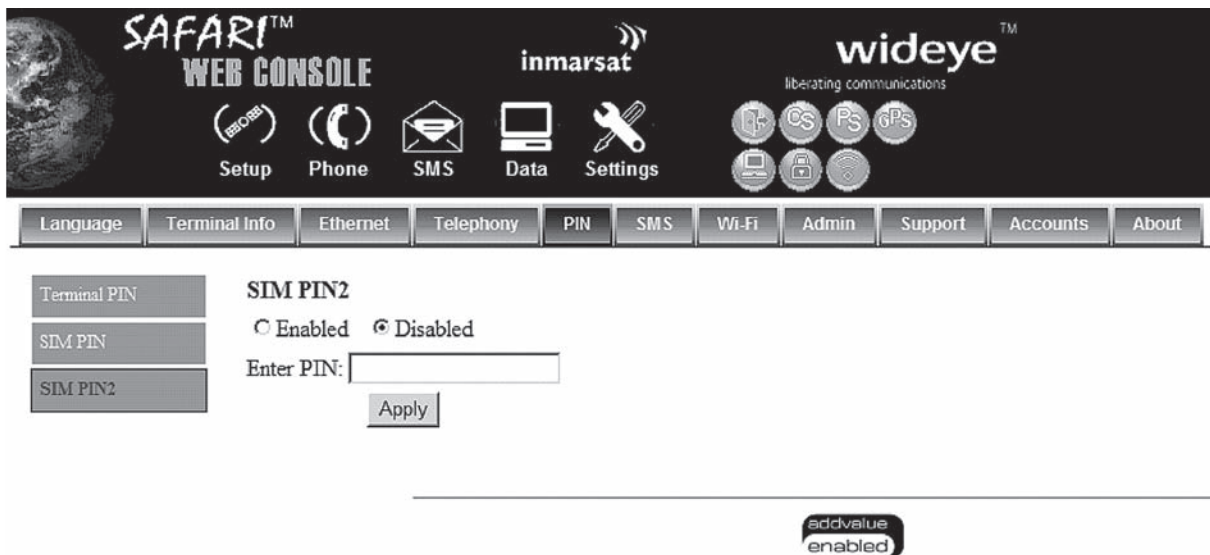

SMS

To change the **SMS service Center Address** number, enter the new number in the space provided and click **Update**.

The screenshot shows the Safari Web Console interface. At the top, there are logos for SAFARI™ WEB CONSOLE, inmarsat, and wideye™ liberating communications. Below the logos are navigation icons for Setup, Phone, SMS, Data, and Settings. A horizontal menu contains tabs for Language, Terminal Info, Ethernet, Telephony, PIN, SMS, Wi-Fi, Admin, Support, Accounts, and About. The SMS tab is selected, displaying the 'Service Center Address' section. It features two radio buttons: 'SIM' (unselected) and 'User Defined' (selected). Both radio buttons are followed by text input fields containing the number '+870772001799'. Below the input fields is an 'Update' button. At the bottom right, there is an 'addvalue enabled' logo.

Note:

Please contact your distributor or service provider if you do not know the Service Center Address.

Wi-Fi Module Configuration

- **System info**
 1. Shows you software version and mac address.

The screenshot shows the Safari Web Console interface with the Wi-Fi tab selected. The navigation menu at the top is the same as in the previous screenshot. Below the menu, there are three tabs: 'System Info', 'Wireless Settings', and 'Security Settings'. The 'System Info' tab is active, displaying the following information:
Ethernet MAC Address: 00:02:b3:01:01:1c
WLAN MAC Address: 00:02:b3:01:01:1d
Software Version: addvalue-srgw-em-1.1.37 (2011-03-30-15-52)
At the bottom right, there is an 'addvalue enabled' logo.

- **Wireless Settings**

1. Allow you to enable/disable wireless connection.
2. Choose ideal network mode, channel bandwidth and channel.
3. Allow you to name your network.

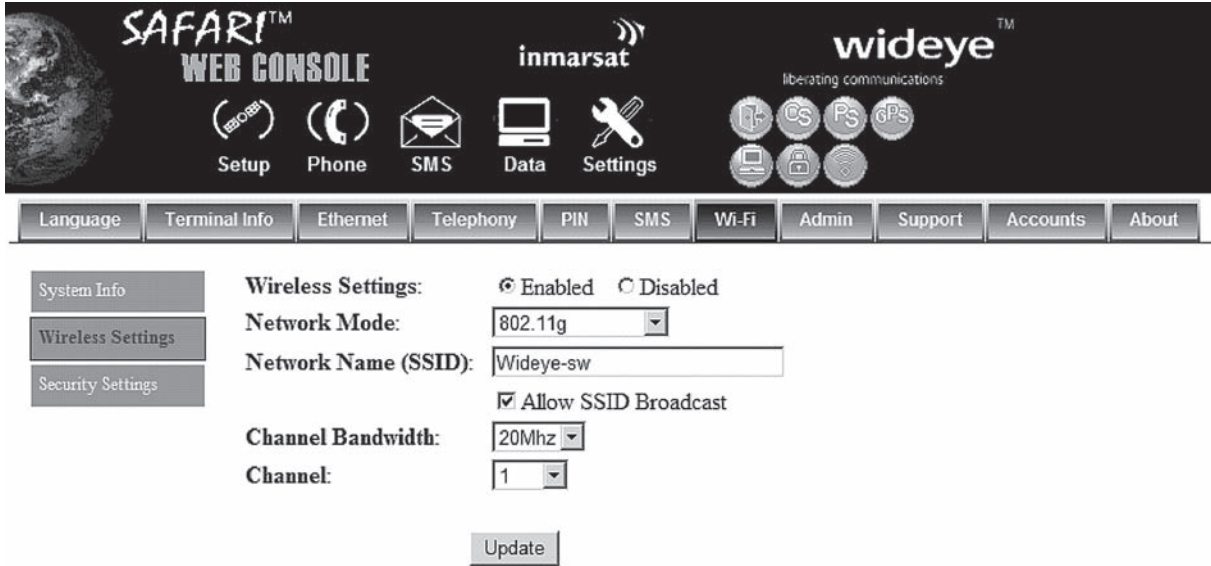

- **Security Settings**

Follow the steps to configure the security settings of the Wi-Fi module.

1. Select the security mode and authentication key.

Note: There are four sets of security passwords available for your security configuration and you can only select one set of password.

2. Select the default key to enable the desire password from Key 1 to Key 4 respectively.

SAFARI™ WEB CONSOLE inmarsat wideye™ liberating communications

Setup Phone SMS Data Settings

Language Terminal Info Ethernet Telephony PIN SMS Wi-Fi Admin Support Accounts About

System Info
Wireless Settings
Security Settings

Security Mode: WEP
Authentication Type: Open Key
Default Key: 1
Key 1: 12345678901234567890123456
Key 2:
Key 3:
Key 4:

Update

WEP Key Instructions:
Enter 10 hex characters for 40/64 bits security.
Enter 26 hex character for 108/128 bits security.
Valid hex characters are digit 0 through 9 and letters A through F.

addvalue enabled

Admin

- **Change Password**

Follow these steps to change the Web Console login Password:

1. Enter the old password in the **Old Password** field.
2. Enter the new password in the **New Password** field.
3. Re-enter the new password in the **Re-type Password** field.
4. Click **Update**.
The Web Console login password is now changed.

The screenshot displays the Safari Web Console Admin interface. At the top, there are logos for SAFARI™ WEB CONSOLE, inmarsat, and wideye™ liberating communications. Below the logos are icons for Setup, Phone, SMS, Data, and Settings. A navigation bar contains buttons for Language, Terminal Info, Ethernet, Telephony, PIN, SMS, Wi-Fi, Admin, Support, Accounts, and About. The main content area features a sidebar with buttons for Change Password, Firmware Upgrade, Reboot Terminal, Factory Reset, Save Settings, GPS Output, Ciphering, Backup/Restore, and Feature. The Change Password form includes three input fields: Old Password, New Password, and Re-type Password, followed by an Update button. At the bottom right, there is a badge that says "addvalue enabled".

- **Firmware Upgrade**

Firmware upgrade is to update your SAFARI™ TU with the latest firmware. Please refer to your respective distributor for your firmware download.

Warning:

DO NOT abort the upgrading process or unplug the power of the SAFARI™ TU during the firmware upgrade process at any time. Doing so will corrupt the existing firmware loaded onto the SAFARI™ TU.

Follow these steps to upgrade the firmware for your SAFARI™ TU:

1. Download or acquire the new firmware from your respective distributor and save it in your computer's hard drive.

Note:

Make sure the SAFARI™ TU is switched on and connected to the desktop/laptop computer using the LAN cable.

2. Select Firmware Upgrade.

Read the **Disclaimer** message carefully before proceeding with the Firmware Upgrade.

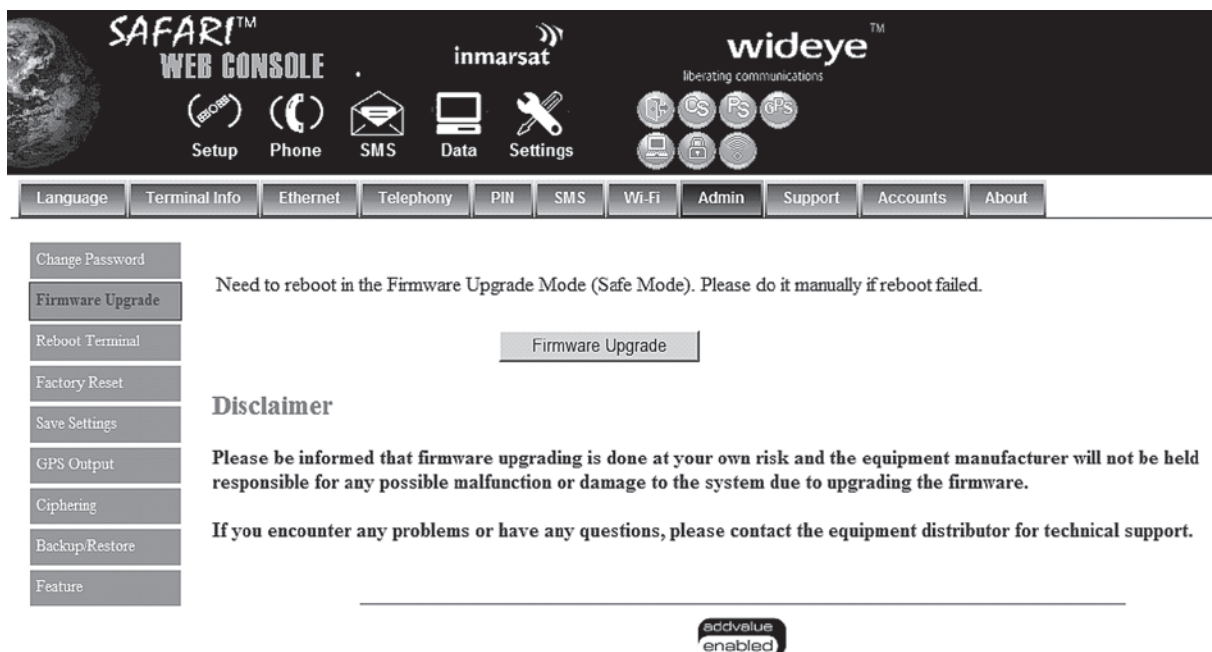

3. Click **Firmware Upgrade**.
The SAFARI™ TU will reboot into Safe mode.

Note: All LEDs will turn to amber color and start blinking, which means it's on Safe mode.

Waiting for Terminal to reboot into safe mode.

4. The SAFARI™ **Web console** will appear. Re-log in using the provided username and password.

Note: If the SAFARI™ web console didn't appear, you can manually refresh the web console by clicking the F5 on your keyboard.

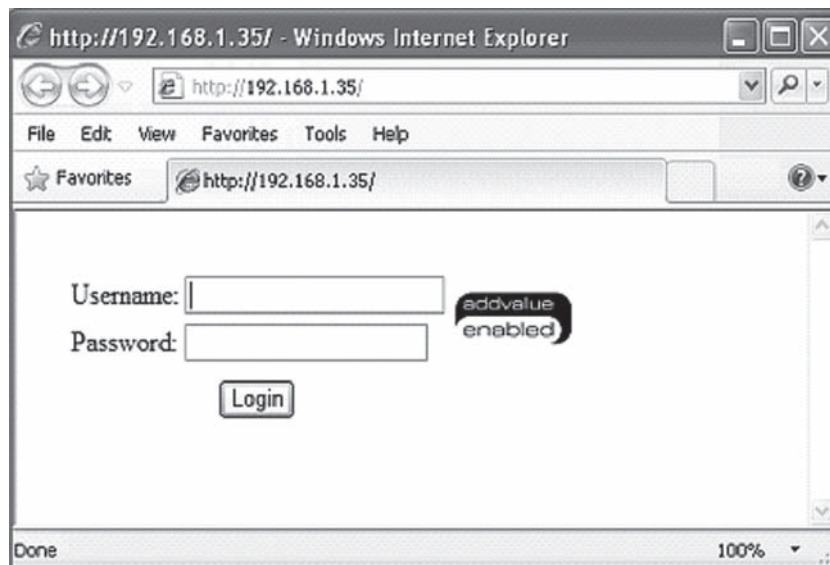

5. Browse to the location of the new firmware, select, and click **Upload**.
6. Firmware upgrade will take approximately 10 to 12 minutes to complete.
You will be prompted with the **Result: Firmware Upgrade Completed** message.

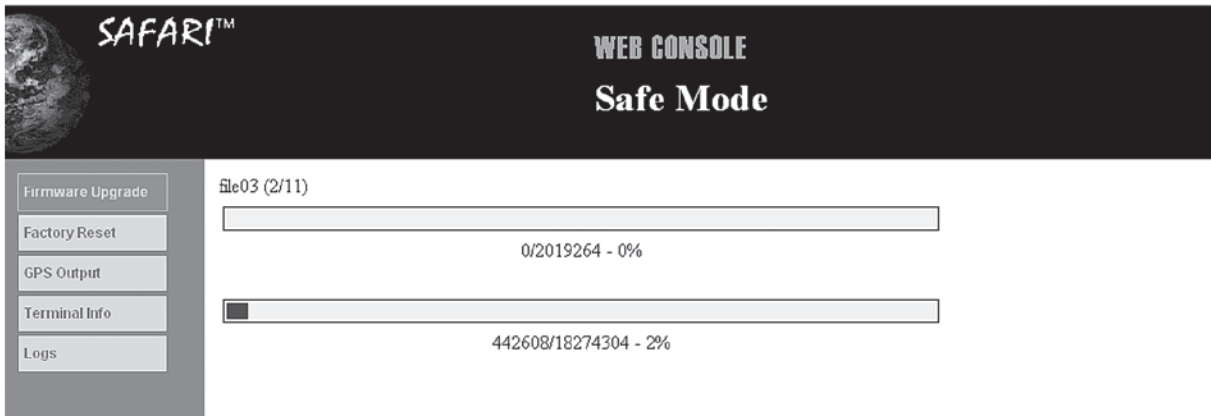

7. Click **Reboot Terminal** to reboot the SAFARI™ TU.



- **Reboot Terminal**

If you wish to reboot the SAFARI™ TU, click **Reboot Terminal**. Click **Reboot** and wait for a few minutes to allow the TU to reboot. Refresh your browser to update the Web Console page after reboot.

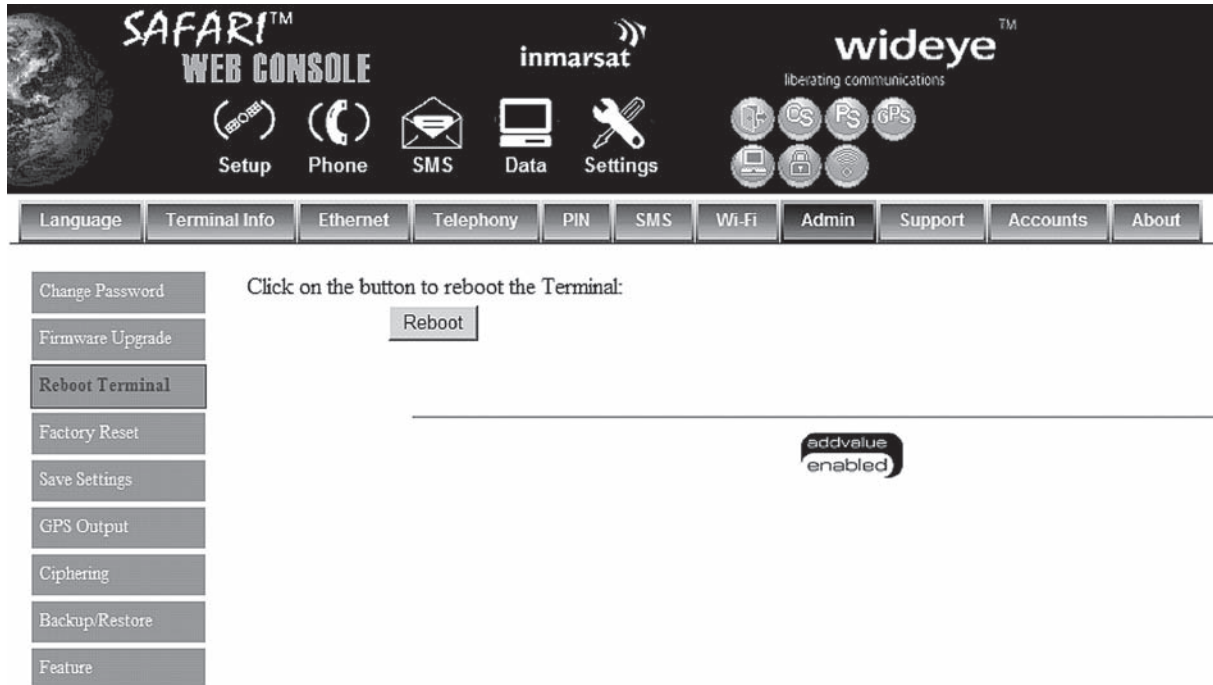

- **Factory Reset**

To perform a Factory Reset, enter the Security code **0000** and click **Factory Reset**.

Warning:

All the settings and user data (e.g., Phone Book, GPS, etc.) of the SAFARI™ TU will be cleared and reset to the default settings. If you do not wish to lose critical user data such as Phone Book, please use limited reset option available via Primary Handset

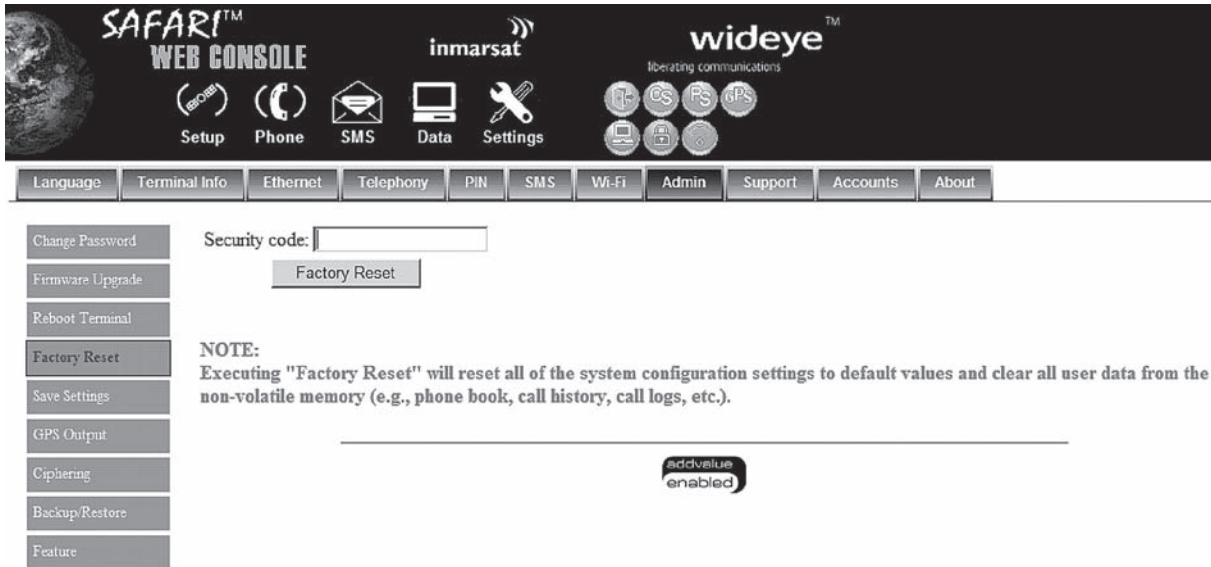

- **Save Settings**

To power down the SAFARI™ TU Transceiver Unit using the main power switch, it is recommended to save the recent setting changes. To save the recent changes, click **Save Now**.

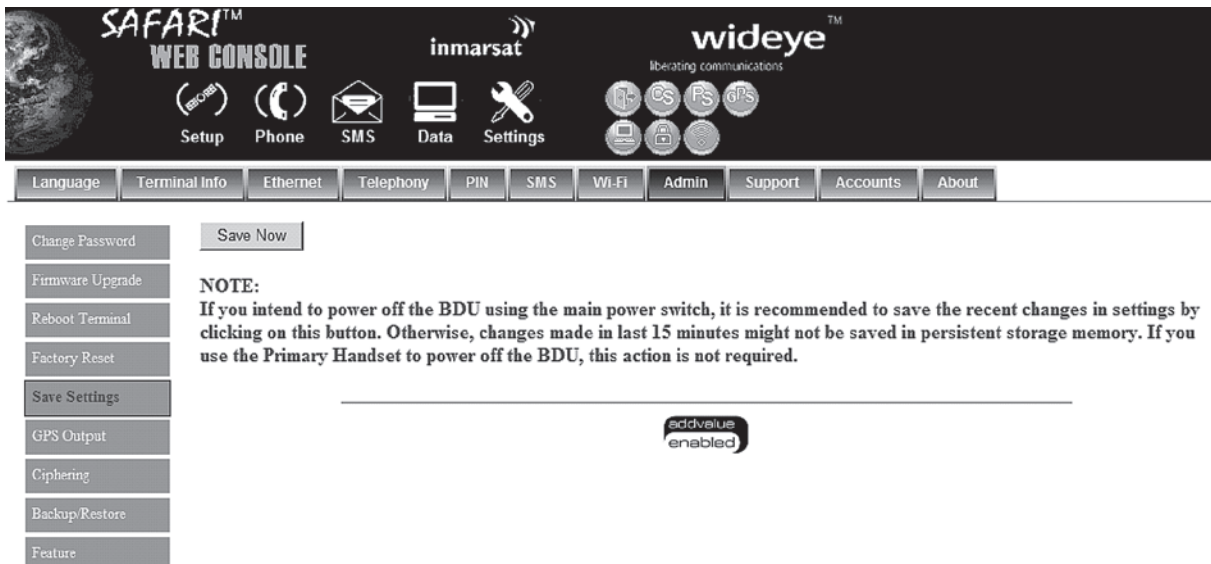

- **GPS Output**

By default, SAFARI™ TU Transceiver Unit outputs the GPS data in NMEA format (at 9600bps) via the **NMEA 0183 Connector for GPS output**. For technician who wants to diagnose the system, he/she may collect the debug log messages by selecting **Output Debug Log**. Since the debug mode is not required for normal users, it is recommended not to make any changes to this setting.

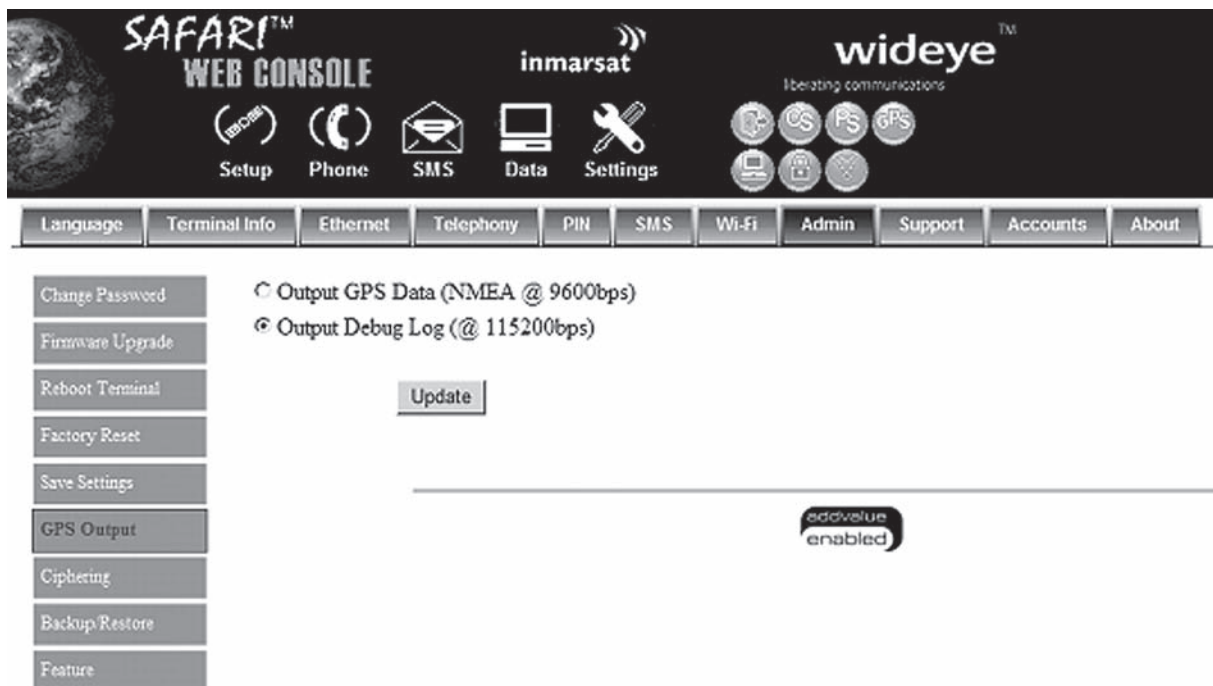

- **Ciphering**

Enabling the **Ciphering** option will make the SAFARI™ TU to exchange voice and data in secure mode by encrypting them over the air. To enable/disable the **Ciphering**, select the option **Enabled** or **Disabled** respectively and click **Update** to make the change to take effect.

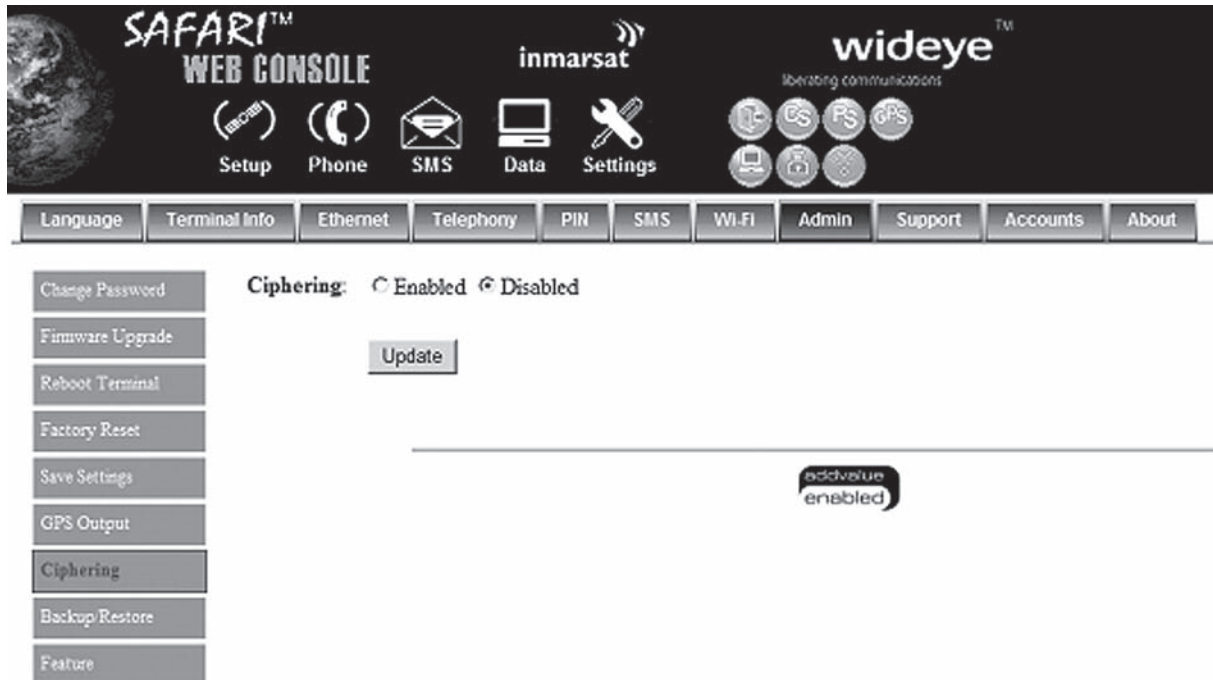

- **Backup/Restore**

If you wish to backup your current settings, you may choose Full backup or Partial Backup:

1. Full backup – This apply only on the same terminal and not for distribution.
2. Partial backup – It allows distribution of certain settings to many terminals of the same Model and Firmware version.

To restore the previous backup settings, you may click on **Browse** to locate the backup file and restore accordingly.



- **Feature**

Displays the Optional Feature for Fax enabled. To activate the Fax feature, activation PIN is required. Please contact your DP for assistance.



- **Support**

Display information of the support telephone number, support email address, Support URL and Services URL. (The information shown is for sample purpose only.)

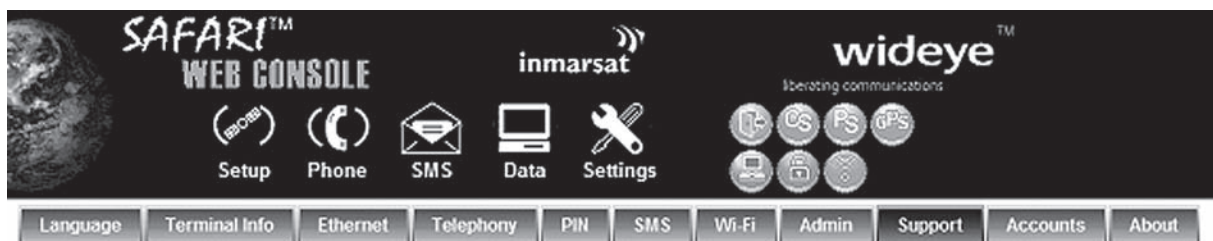

Inmarsat Distribution Partner Name:	BETA TEST DATA
Phone Number For Support:	+442077281653
Support E-Mail Address:	BGANTEST1@INMARSAT.COM
Support URL:	http://SUPPORT.INMARSAT.COM/MMI1.ASPX
Services URL:	http://SUPPORT.INMARSAT.COM/MMI2.ASPX



- **Accounts**

1. Select **Add** to add new user.
2. Select **Delete** to delete specific user.
3. Select **Change Password** to change specific user's password.

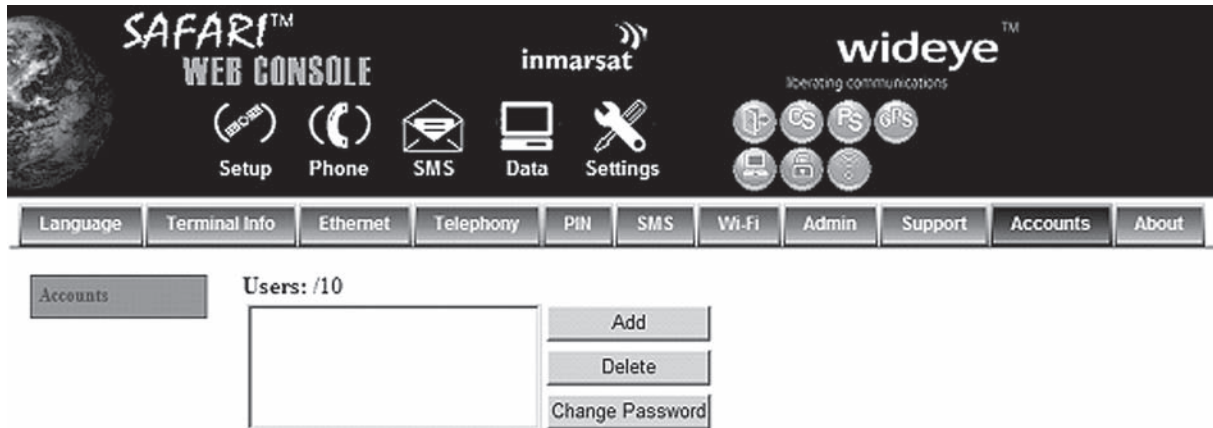

- **About**

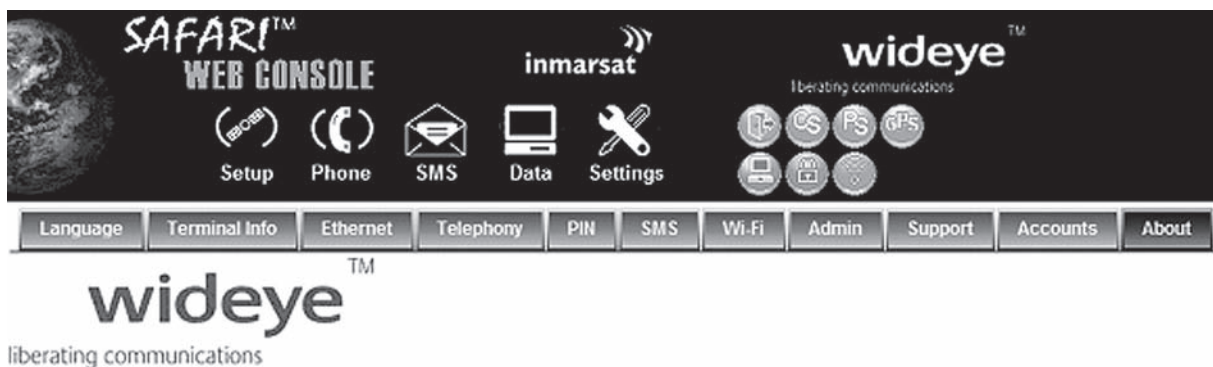

Copyright © 2011 Addvalue Technologies Ltd.
All rights reserved.

Available interfaces

There are multiple connectors available on the SAFARI™ Transceiver Unit for connecting to different types of devices:

1. LAN RJ45 (PoE) connector for standard Ethernet LAN Connection
2. G3 FAX RJ11 connector connecting to the fax machine
3. Standard Analog Corded or Cordless Phone RJ11 connector for voice call
4. GPS output RJ11 connector (Offset) in NMEA 0183 format
5. Primary Handset circular connector for voice call and Transceiver Unit's configuration settings
6. GPIO circular connector connecting to external devices
7. LAN RJ45 connector for standard Ethernet LAN Connection

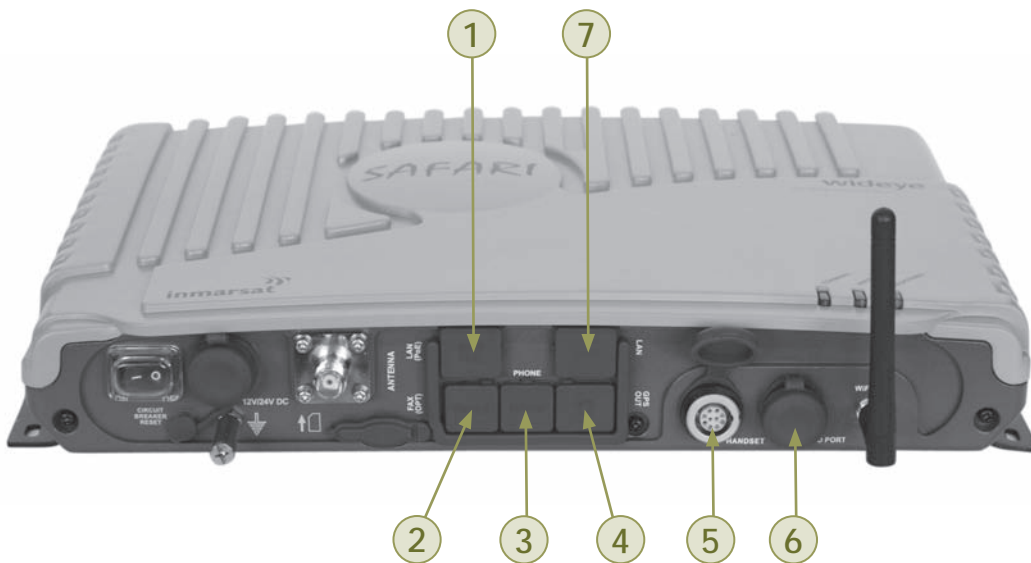

Standard Analog Phone RJ11 Connector for Voice ③

The Transceiver Unit has a dedicated connector labeled as “Phone” for connecting to a standard analog phone.

Primary Handset Circular Connector ⑤

The Transceiver Unit has a dedicated circular connector for connecting to the Primary Handset.

Ethernet LAN (PoE) RJ45 Connector for DATA

The Transceiver Unit has two Ethernet (LAN) RJ45 connectors with one connector supports the Power over Ethernet (PoE).

Please refer to ① for Ethernet LAN PoE connector

Please refer to ⑦ for standard Ethernet LAN connector

GPS Output RJ11 (Offset) Connector ④

The Transceiver Unit has a GPS output RJ11 (Offset) connector for outputting the GPS data in NMEA0183 format.

G3 FAX RJ11 Connector ②

The Transceiver Unit has a dedicated Fax connector for connecting to a fax machine.

Please note that FAX is an optional feature and hence user has to purchase the activation PIN to activate before using it.

Note: FAX works only at locations where the satellite elevation angle is >45°.

GPIO Circular Connector ⑥

The Transceiver Unit has a dedicated circular connector to provide GPIO (General Purpose Input/Output) interface to the external devices (Please refer to Appendix B for detailed information)

IP 44 Protection

The SAFARI™ Transceiver Unit meets or exceeds IP 44 requirements for environmental protection, i.e. dust and water, provided the TU is used with the included RJ11 phone cord, RJ45 LAN cables and the Primary Handset. To maintain proper environmental protection, care should be taken to ensure that the cables are connected such that the connector “lip” fits over the raised edge surrounding the corresponding port.

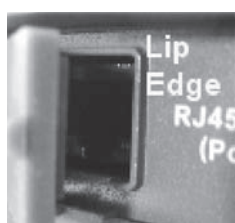
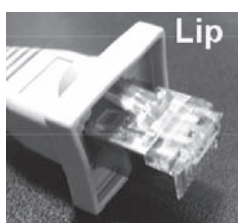

Connecting To a Computer

To connect a computer to the SAFARI™ Transceiver Unit you need a LAN (Category 5) Cable.

1. Plug one end of the LAN cable to one of the RJ45 ports meant for DATA and the other end to your computer LAN port.
2. Use the Web Console as listed in the **Data Menu** section of Chapter 4 - Using the Web Console, to configure the SAFARI™ Transceiver Unit and activate a data connection.

Using a Standard Phone

You can connect a standard analog corded or cordless phone to the **PHONE** port using the included IP44 rated RJ11 phone cable to make and receive voice calls.

When there is an incoming standard voice call, all the phones connected to those ports will ring. Once one of them answers the call, all other phones will stop ringing.

5 Troubleshooting and FAQs

LEDs Signalling

General LED status

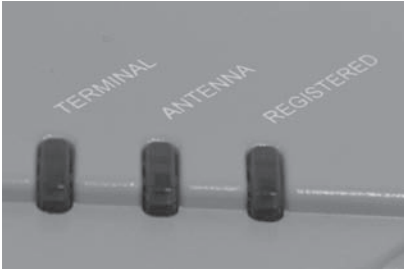

Transceiver Unit LED

LED behavior	Descriptions / Remedial Actions
Off	Transceiver Unit is in power-off state.
Steady amber	Transceiver Unit is powering up.
Steady green	Transceiver Unit has powered up successfully.
Steady red	System failure during boot up or operation. User action required.

Antenna LED

LED behavior	Descriptions / Remedial Actions
Off	ANTENNA status unknown.
Steady amber	ANTENNA is powering up.
Blinking amber	ANTENNA is calibrating.
Blinking green	ANTENNA is scanning for satellite.
Steady green	ANTENNA is tracking a satellite and ready for use.
Steady red	System failure in ANTENNA. User action required.

Network Registration LED

LED behavior	Descriptions / Remedial Actions
Off	BGAN registration has not started. Network service unknown.
Blinking green	Ready for packet data only.
Steady green	BGAN registration succeeded. Full network service available.
Blinking amber	Ready for voice only.
Steady red	System failure in BGAN network registration. User action required.

SIM Card

Symptoms	Descriptions / Remedial Actions
SIM Card cannot be detected by transceiver	<ul style="list-style-type: none">• Ensure that a correct Inmarsat SIM card is used.• Ensure that a SIM card is properly inserted into SIM Card Slot• Retry by re-inserting the SIM card into SIM Card Slot before powering up the Transceiver.
Transceiver indicates “Wrong SIM Card”	<ul style="list-style-type: none">• Ensure that a correct SIM card is used.

GPS Output

Symptoms	Descriptions / Remedial Actions
Unable to acquire GPS even after a long time	<ul style="list-style-type: none">• Ensure that there is no blockage for the antenna.• Ensure that the antenna cable is secured properly.
No NMEA string output from the GPS output port	<ul style="list-style-type: none">• Ensure that there is a proper connection at the GPS output port.• Ensure that the GPS output is set to Output NMEA data via the Web Console.

PoE LAN Port (RJ45)

Symptoms	Descriptions / Remedial Actions
No LAN indication	<ul style="list-style-type: none">• Ensure that the Ethernet Cable is plugged into the PoE LAN port (RJ45) or the standard LAN port (RJ45) correctly.• Check to ensure that the Ethernet Port on your PC / Laptop is working fine.
Unable to acquire IP address. My PC shows “Limited connectivity”	<ul style="list-style-type: none">• Try to unplug and plug the Ethernet Cable.• Try to reboot the Transceiver.• Try to restart your PC/Laptop.
Unable to ping my Transceiver	<ul style="list-style-type: none">• Ensure that the LAN indication LED is active.• Ensure that the IP address of the transceiver is set correctly.• Make sure that there is no firewall or proxy settings in your PC/ laptop that prevent access to the transceiver.

RJ11 Phone Port for Standard Call

Symptoms	Descriptions / Remedial Actions
Unable to make outgoing call	<ul style="list-style-type: none">• Make sure that there is dial tone before making the call. For the case of busy tone,<ul style="list-style-type: none">◦ Ensure that the line is not engaged by any other telephone services.◦ Ensure that all other telephony devices are hung up properly.• For the case of no dial tone,<ul style="list-style-type: none">◦ Ensure that the phone line is connected to the phone port of the transceiver.• Hang up and retry the call again.
Unable to receive incoming call	<ul style="list-style-type: none">• Ensure that a correct call number is used• Ensure that the line is not engaged by any other telephony devices.• Ensure that all other telephony devices are hung up properly.
Distorted audio during outgoing/incoming call	<ul style="list-style-type: none">• The audio may clip when use with some phones in high volume. Please lower the volume of the phone in such situation.• Please temporarily disconnect any data connection since high throughput may affect the quality of the audio.• Hang up and retry the call again.

Primary Handset

Symptoms	Descriptions / Remedial Actions
No display / power for Primary handset	<ul style="list-style-type: none"> • Check the DC power supply input to the transceiver. • Check the primary handset whether it is properly inserted to the handset port.
Unable to connect to the transceiver	<ul style="list-style-type: none"> • Ensure the primary handset is inserted to the handset port.
Unable to make outgoing call	<ul style="list-style-type: none"> • Ensure a correct call number to be dialed. • Hang up the handset and retry the call.
Unable to receive incoming call	<ul style="list-style-type: none"> • Ensure a correct call number is used. • Ensure that the line is not engaged by any other telephony devices. • Ensure all other telephony devices are hung up properly.
No audio during incoming/ outgoing call	<ul style="list-style-type: none"> • Ensure the Primary Handset connector is inserted into the port properly. • Hang up and retry the call again. • Try to reboot the Transceiver Unit.
Distorted audio during incoming/ outgoing call	<ul style="list-style-type: none"> • Lower the volume of the Primary Handset. • Please temporarily disconnect any background data connection since high throughput may affect the quality of the audio. • Hang up and retry the call.

Web Concole

Symptoms	Descriptions / Remedial Actions
Unable to access Web Console	<ul style="list-style-type: none"> • Ensure that there is no problem with the Ethernet connectivity. • Ensure that IP address is entered correctly.
Unable to login	<ul style="list-style-type: none"> • Ensure that the correct username and password are used (case sensitive). • Ensure that you do not open more than the maximum Web Console sessions allowed. • Retry by closing and reopening the web browser.
Web page does not seem to be updated or there are unexpected errors occurred.	<ul style="list-style-type: none"> • Refresh the web page. • Update the web browser to the latest version and retry.

Data Connection

Symptoms	Descriptions / Remedial Actions
Unable to active Primary PDP context	<ul style="list-style-type: none"> • Ensure you are using a valid APN. • For static IP connection, please make sure that your user name and password are correct. • Ensure your SIM card supports PS services.
Unable to access internet after successfully Primary PDP context activation	<ul style="list-style-type: none"> • Make sure that your PC/laptop is using dynamic IP assignment or a correct gateway should be specified if using static IP. • Make sure that there is no firewall or proxy settings in your PC/laptop that prevent access to the transceiver.
“Auto Connect (Last successfully Activated PDP Context)” feature is not working	<ul style="list-style-type: none"> • Make sure that this feature is enabled via Web Console. • A standard background connection has to be successfully activated for the first time after enabling this feature. • This feature takes no effect if last activated PDP context is of streaming class or current data connection is terminated by the user. • Please wait for at least 1 minute for re-connection if any error happened during connection time.

Safe Mode and Firmware Upgrade

Symptoms	Descriptions / Remedial Actions
Unable to enter safe mode. Transceiver continues to start in normal mode.	<ul style="list-style-type: none"> • Make sure that the safe mode button (the button besides the SIM card slot) is pressed and held tightly until all LEDs turn into amber colour.
Firmware upgrade fails	<ul style="list-style-type: none"> • Make sure that you are using the correct firmware upgrade package. • Make sure that there is no interruption of power supply during firmware upgrade. • Retry firmware upgrade.

Antenna / Satellite Signal Level

Symptoms	Descriptions / Remedial Actions
Low Signal Strength	<ul style="list-style-type: none"> • Check any obstruction such that may block the Antenna Unit's line of sight. • Check any interference signal from other electronics devices that are close to the antenna unit. • Check to ensure that the antenna cable is properly secured. • Depending on the antenna's location on the roof top of the vehicle, the vehicle travelling route may cause the Antenna Unit's line of sight to be blocked by any objects such as trees, mountain, buildings or overhead bridge depending on the elevation of the satellite.

System fails to power up

Symptoms	Descriptions / Remedial Actions
No light appear on Transceiver LED.	<ul style="list-style-type: none"> • Ensure the power switch on the front panel is at "On" position. • To reset the circuit breaker on the front panel by depressing the lever of the circuit breaker inward fully and release. • Check the main power source to the Transceiver unit either from the cigarette lighter socket of the vehicle's dashboard console or the car battery as below, <ul style="list-style-type: none"> ◦ If the power source is from the cigarette lighter socket of the vehicle's dashboard console, use the vehicle cigarette lighter to test the existence of the power source. Else, check the fuse in the cigarette lighter connector of the power cable to ensure that it is not blown. ◦ If the power source is directly from the vehicle battery, turn on the vehicle's engine to test the existence of the power source. If the vehicle's engine can be started, check the fuse in the fuse box connecting to the car battery.

Appendix A

Technical Specifications

A.1 Transceiver's Outline Dimensions

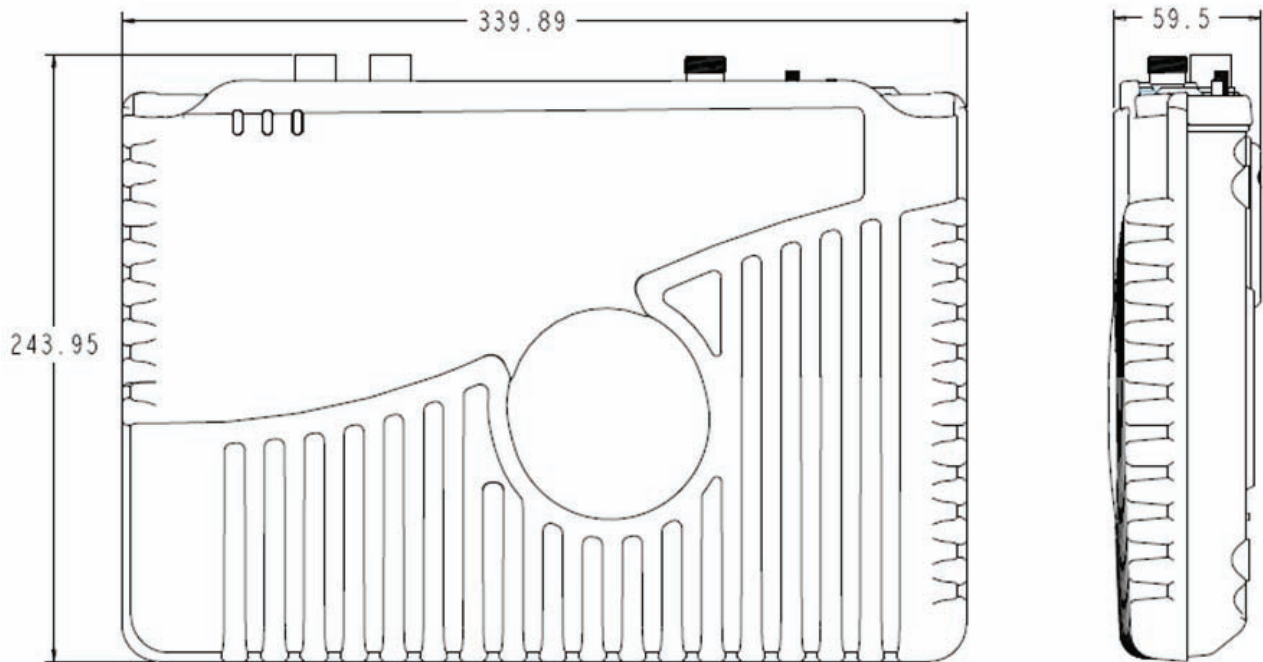

A.2 Antenna's Outline Dimensions

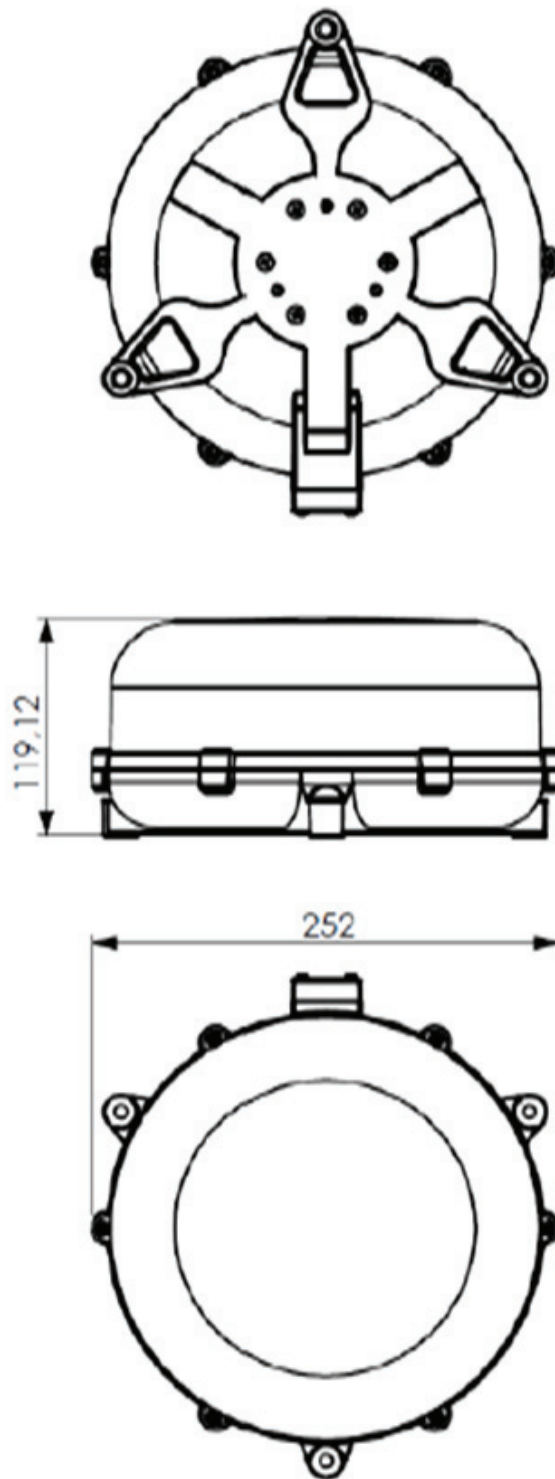

Weight: 2 kg.

Dimensions are expressed in terms of mm.

A.3 Primary Handset's Outline Dimensions

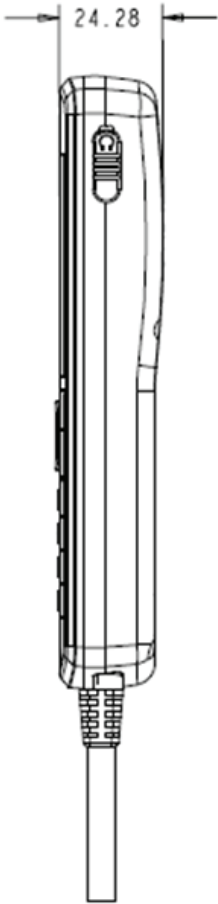
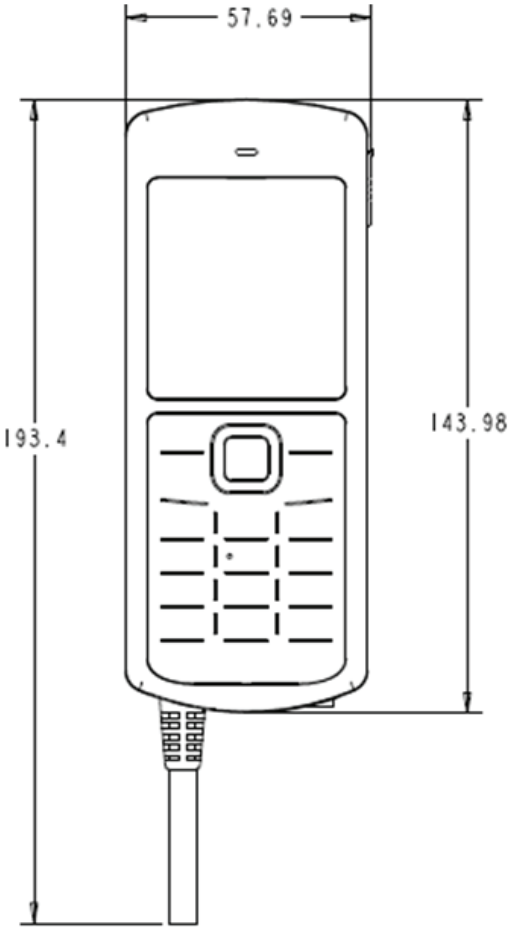

NOTE:
DIMENSION ON MM UNIT

Appendix B

This section describes the GPIO cable connections and its recommended peripherals.

GPIO Cable Connection

GPIO Plug	Signal Name	Type of Wire	Color Code	No-connector
GPIO-1	Reserved	AWG 24 Unscreened Wire	Black	Unterminated
GPIO-2	Ground	AWG 24 Unscreened Wire	Brown	Unterminated
GPIO-3	Ignition (Active High)	AWG 24 Unscreened Wire	Red	Unterminated
GPIO-4	LED	AWG 24 Unscreened Wire	Orange	Unterminated
GPIO-5	Remote On/Off	AWG 24 Unscreened Wire	Yellow	Unterminated
GPIO-6	Buzzer	AWG 24 Unscreened Wire	Green	Unterminated
GPIO-7	Ground	AWG 24 Unscreened Wire	Blue	Unterminated
GPIO-8	Transmitter Off	AWG 24 Unscreened Wire	Purple	Unterminated
GPIO-9	10V supply	AWG 24 Unscreened Wire	Grey	Unterminated
GPIO-10	Reserved	AWG 24 Unscreened Wire	White	Unterminated
GPIO-11	No connection	-	-	-
GPIO-12	No connection	-	-	-

CONNECTION DETAIL		
A	COLOR	B
1	BLACK(黑色)	TIN
2	BROWN(棕色)	TIN
3	RED(紅色)	TIN
4	ORANGE(橙色)	TIN
5	YELLOW(黃色)	TIN
6	GREEN(綠色)	TIN
7	BLUE(藍色)	TIN
8	PUEPLE(紫色)	TIN
9	GREY(灰色)	TIN
10	WHITE(白色)	TIN
11	NC	
12	NC	

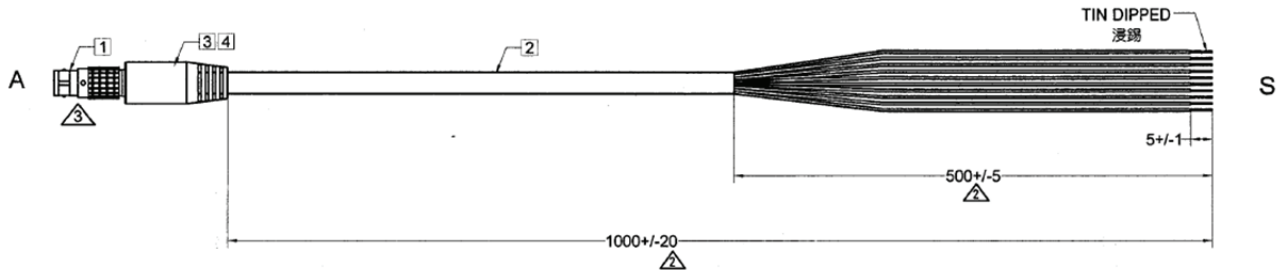

Recommended GPIO Peripherals

Below are peripherals recommended for the GPIO connections.

1. Remote On/Off Switch - GPIO-5

- Manufacturer: APEM
- Manufacturer part number: IRC7Z232LOG
- <http://sg.element14.com/apem/irc7z232log/switch-nc-no-square-grn-led-ip67/dp/1714239?Ntt=1714239>

Remote “On/Off” switch electrical connection diagram

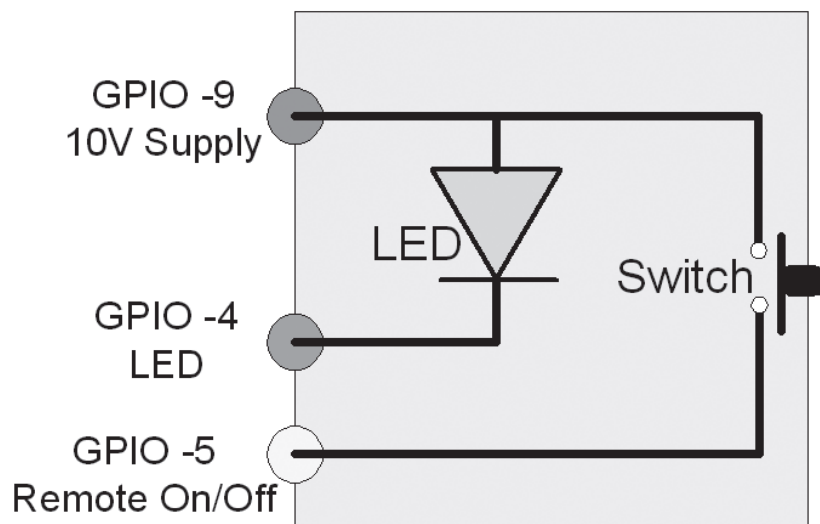

Depress the Remote “On/Off” switch to turn “ON” and “OFF” the Safari with the LED as an indicator to display the Safari™ operating status.

LED ON	SAFARI™ is in the operating
LED OFF	SAFARI™ is shutdown

2. Buzzer - GPIO-6

- a. Buzzer 12V
 - Manufacturer: MOFLASH SIGNALLING
 - Manufacturer p/n: AE20M-12FA
 - <http://sg.element14.com/moflash-signalling/ae20m-12fa/buzzer-piezo-12v-ac-dc/dp/1649236?Ntt=1649236>
- b. Buzzer 24V
 - Manufacturer: MOFLASH SIGNALLING
 - Manufacturer p/n: AE20M-24FA
 - <http://sg.element14.com/moflash-signalling/ae20m-24fa/buzzer-piezo-24v-ac-dc/dp/1649237?Ntt=1649237>

The Buzzer electrical connection diagram

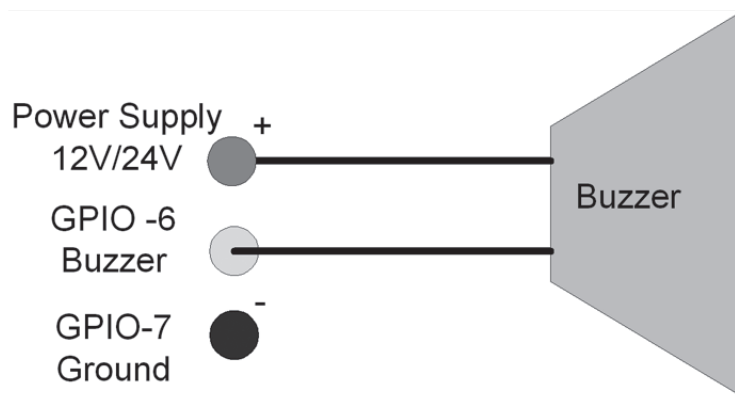

The GPIO-6 Buzzer low side driver can sink current up to maximum of 500 mA.

3. Transmitter “Off” Switch – GPIO-8

- Manufacturer: ARCOLECTRIC SWITCHES
- Manufacturer p/n: C1350XBAAA
- <http://sg.element14.com/arcolectric-switches/c1350xbaaa/rocker-switch-dpst-black-red-i/dp/273247?Ntt=273247>

Transmitter “Off” switch connection diagram

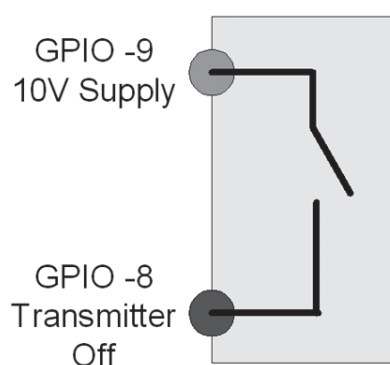

4. Ignition

- Connect the GPIO-3 to the “ACC” contact of the ignition switch as shown in the diagram below if the voltage level of the “ACC” contact of the ignition switch is “High” (+12Vdc or +24Vdc) when the Ignition switch is being switched “On”.

